

# ***TECHNOBEAM***<sup>®</sup>

## **User Manual**

© High End Systems, Inc. 1998-2004, All Rights Reserved

Information and Specifications in this document are subject to change without notice. High End Systems, Inc. assumes no responsibility or liability for any errors or inaccuracies that may appear in this manual. .

Technobeam User Manual  
P/N 60600115 Version 2.1 June, 2004  
Printed in the U.S.A.

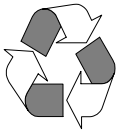

# Trademarks

---

Trademarks used in this text: High End Systems, Technobeam, LAD, Intellabeam, Emulator, Dataflash, Fusion Fire and LithoPatterns and Laser Aiming Device are registered trademarks of High End Systems, Inc.

Belden is a registered trademark of Belden, Inc. Philips is a registered trademark of Philips Lighting Company. ETL and CETL are registered trademarks of Intertek Testing Services. Other trademarks and trade names may be used in this document to refer to either the entities claiming the marks and names or their products. High End Systems disclaims any proprietary interest in trademarks and trade names owned by others.

# Patents

---

This product may use one or more of the following patents: US 4,392,187; US 4,602,321; US 4,688,161; US 4,701,833; US 4,709,311; US4,779,176; US 4,800,474; US 4,962,687; US 4,972,306; US 4,980,806; US 5,010,459; US 5,031,078; US 5,073,847; US 5,078,039; US5,186,536; US 5,209,560; US 5,278,742; US 5,282,121; US 5,307,295; US 5,329,431; US 5,331,822; US 5,367,444; US 5,402,326; US 5,430,629; US 5,432,691; US 5,454,477; US 5,455,748; US 5,506,762; US 5,515,254; US 5,537,303; US 5,545,951; US 5,580,164; US 5,590,954; US 5,590,955; US 5,640,061; US 5,647,662; US 5,665,305; US 5,691,886; US 5,728,994; US 5,758,955; US 5,758,956; US 5,769,527; US 5,774,273; US 5,798,619; US 5,806,951; US 5,823,661; US 5,825,548; US 5,828,485; US 5,829,868; US 5,857,768; US 5,882,107; US 5,934,794; US 5,940,204; US 5,945,786; US 5,953,152; US 5,980,066; US 6,048,080; US 6,327,103; US 6,048,081; US6,057,958; US 6,054,816; US 6,126,288; US 6,142,652; US 6,172,822; US 6,188,933; US 6,208,087; US 6,219,093; US 6,220,730; US6,241,366; US 6,255,787; US 6,256,136; US 6,278,542; US 6,288,828; US 6,327,103; US 6,421,165; US 6,430,934; US 6,466,357; US 6,502,961; US D347,113; US D350,408; US D359,574; US D360,404; US D365,165; US D366,712; US D370,080; US D372,550; US D377,338; US D381,740; US D409,771; EP 0662275; EP 0767398; DE 621495; DE 655144; DE 797503; EP 0475082; GB 2 043 769 B; GB 2 055 842 B; GB 2 283 808 B; GB 2 290 134 B; GB 2 291 814 B; GB 2 292 530 B; GB 2 292 896 B; GB 2 294 909 B; GB 2 295 058 B; GB 2 303 203 B; GB 2 306 887 B; GB 2 307 036 B; GB 2 316 477 B; MR0862-1996; M9,604,224.9; US 6693392; US 6719433

Additional patents pending.

# ***FCC Information***

---

This equipment has been tested and found to comply with the limits for a Class A digital device, pursuant to part 15 of the FCC rules. These limits are designed to provide reasonable protection against harmful interference when the equipment is operated in a commercial environment. This equipment generates, uses, and can radiate radio frequency energy and, if not installed and used in accordance with the instruction manual, may cause harmful interference to radio communications. Operation of this equipment in a residential area is likely to cause harmful interference in which case the user will be required to correct the interference at his own expense.

# Declaration of Conformity

according to ISO/IEC Guide 22 and EN45104

**Manufacturer's name:** High End Systems Inc.  
**Manufacturer's address:** 2105 Gracy Farms Lane  
Austin, Texas 78758 U.S.A.

**Distributor's name:** High End Systems Inc.  
**Distributor's address:** 2105 Gracy Farms Lane  
Austin, Texas 78758 U.S.A.

Declares that the product

**Product Name:** Technobeam  
**Product Number:** All  
**Product Options:** All

conforms to the following EEC directives:  
73/23/EEC, as amended by 93/68/EEC  
89/336/EEC, as amended by 92/31/EEC and 93/68/EEC

Equipment referred to in this declaration of conformity first manufactured in 1997 in compliance with the following standards:

**Safety:** EN 60598-1 : 1993  
EN 60598-2-17 : 1989  
A1-A3 : 1993  
EN 60825-1, 1994

**EMC:** EN 55022, Class A ITE  
IEC 801-2, 1991 Level 2 (4/8 kV)  
IEC 801-3, Draft 5 Level 2 (3 V/m)  
IEC 801-4, 1988 Level 2 (1 kV/0.5 kV)



U.S.A., June 21, 2004  
Kenneth Stuart Hansen, Compliance Engineer



# ***Important Safety Information***

---

Instructions pertaining to continued protection against fire, electric shock, exposure to excessive ultraviolet (UV) radiation, and injury to persons are found in Appendix D.

Please read all instructions prior to assembly, mounting, and operating this equipment.

## **IMPORTANT: INFORMATIONS DE SÉCURITÉ**

Les instructions se rapportant à la protection permanente contre les incendies, l'électrocution, l'exposition à un rayonnement ultraviolet (UV) excessif et aux blessures corporelles se trouvent dans l'Annexe D.

Veillez lire toutes les instructions avant d'assembler, de monter ou d'utiliser cet équipement.

## **WICHTIGE SICHERHEITSHINWEISE**

Sicherheitsanleitungen zum Schutz gegen Feuer, elektrischen Schlag, übermäßige UV-Strahlung und Verletzung von Personen finden Sie in Anhang D.

Vor der Montage, dem Zusammenbau und der Inbetriebnahme dieses Geräts alle Anleitungen sorgfältig durchlesen.

## **INFORMAZIONI IMPORTANTI DI SICUREZZA**

Le istruzioni sulla protezione da incendi, folgorazione, esposizione eccessiva a raggi ultravioletti (UV) e infortuni sono contenute nell'appendice D.

Si prega di leggere tutte le istruzioni prima di assemblare, montare e azionare l'apparecchiatura.

## **INFORMACION IMPORTANTE DE SEGURIDAD**

En el Apéndice D de este manual se encuentran instrucciones sobre protección continua contra incendios, descarga eléctrica, exposición excesiva a radiación ultravioleta (UV) y lesiones personales.

Lea, por favor, todas las instrucciones antes del ensamblaje, montaje y operación de este equipo.

# ***Product Modification Warning***

---

High End Systems products are designed and manufactured to meet the requirements of United States and International safety regulations. Modifications to the product could affect safety and render the product non-compliant to relevant safety standards.

## ***Mise En Garde Contre La Modification Du Produit***

Les produits High End Systems sont conçus et fabriqués conformément aux exigences des règlements internationaux de sécurité. Toute modification du produit peut entraîner sa non conformité aux normes de sécurité en vigueur.

## ***Produktmodifikationswarnung***

Design und Herstellung von High End Systemen entsprechen den Anforderungen der U.S.A. und den internationalen Sicherheitsvorschriften. Abänderungen dieses Produktes können dessen Sicherheit beeinträchtigen und u. U. gegen die diesbezüglichen Sicherheitsnormen verstoßen.

## ***Avvertenza Sulla Modifica Del Prodotto***

I prodotti di High End Systems sono stati progettati e fabbricati per soddisfare i requisiti delle normative di sicurezza statunitensi ed internazionali. Qualsiasi modifica al prodotto potrebbe pregiudicare la sicurezza e rendere il prodotto non conforme agli standard di sicurezza pertinenti.

## ***Advertencia De Modificación Del Producto***

Los productos de High End Systems están diseñados y fabricados para cumplir los requisitos de las reglamentaciones de seguridad de los Estados Unidos e internacionales. Las modificaciones al producto podrían afectar la seguridad y dejar al producto fuera de conformidad con las normas de seguridad relevantes.

# ***Warranty Information***

---

## ***Limited Warranty***

Unless otherwise stated, your product is covered by a two (2) year parts and labor limited warranty. The Laser Aiming Device (LAD™) for Technobeam is covered by a six (6) month parts and labor limited warranty. Dichroic filters and LithoPatterns® high resolution glass gobos are not guaranteed against breakage or scratches to coating. It is the owner's responsibility to furnish receipts or invoices for verification of purchase, date, and dealer or distributor. If purchase date cannot be provided, date of manufacture will be used to determine warranty period.

## ***Returning an Item Under Warranty for Repair***

It is necessary to obtain a Return Material Authorization number (RMA#) from your dealer or point of purchase **BEFORE** any units are returned for repair. The manufacturer will make the final determination as to whether or not the unit is covered by warranty. Lamps are covered by the lamp manufacturer's warranty.

Any Product unit or parts returned to High End Systems must be packaged in a suitable manner to ensure the protection of such Product unit or parts, and such package shall be clearly and prominently marked to indicate that the package contains returned Product

units or parts and with a Return Material Authorization (RMA#) number. Accompany all returned Product units or parts with a written explanation of the alleged problem or malfunction. Ship returned Product units or parts to: 2105 Gracy Farms Lane, Austin, TX 78758 USA.

**Please Note:** Freight Damage Claims are invalid for fixtures shipped in non-factory boxes and packing materials.

### ***Freight***

All shipping will be paid by the purchaser. Items under warranty shall have return shipping paid by the manufacturer only in the Continental United States. **Under no circumstances will freight collect shipments be accepted.** Prepaid shipping does not include rush expediting such as air freight. Air freight can be sent customer collect in the Continental United States.

REPAIR OR REPLACEMENT AS PROVIDED FOR UNDER THIS WARRANTY IS THE EXCLUSIVE REMEDY OF THE CONSUMER. HIGH END SYSTEMS, INC. MAKES NO WARRANTIES, EXPRESS OR IMPLIED, WITH RESPECT TO ANY PRODUCT, AND HIGH END SPECIFICALLY DISCLAIMS ANY WARRANTY OF MERCHANTABILITY OR FITNESS FOR A PARTICULAR PURPOSE. HIGH END SHALL NOT BE LIABLE FOR ANY INDIRECT, INCIDENTAL OR CONSEQUENTIAL DAMAGE, INCLUDING LOST PROFITS, SUSTAINED OR INCURRED IN CONNECTION WITH ANY PRODUCT OR CAUSED BY PRODUCT DEFECTS OR THE PARTIAL OR TOTAL FAILURE OF ANY PRODUCT REGARDLESS OF THE FORM OF ACTION, WHETHER IN CONTRACT, TORT (INCLUDING NEGLIGENCE), STRICT LIABILITY OR OTHERWISE, AND WHETHER OR NOT SUCH DAMAGE WAS FORESEEN OR UNFORESEEN.

Warranty is void if the product is misused, damaged, modified in any way, or for unauthorized repairs or parts. This warranty gives you specific legal rights, and you may also have other rights which vary from state to state.

# Table of Contents

## Introduction

Features .....	intro-1
Symbols .....	intro-3
Document Conventions .....	intro-3
Contacting High End Systems .....	intro-4

## Chapter 1 Preparing to Install Your Fixture

Specifications .....	1-2
Optional Accessories .....	1-5
Unpacking the Fixture .....	1-6
Installing the Power Cord Cap .....	1-7
Installing the Yoke .....	1-8
Setting the Fixture Voltage .....	1-10
Setting the Beam Angle .....	1-12

## Chapter 2 Setting Up Your Fixture

Powering On the Fixture .....	2-2
Overview of Controller Operation .....	2-4
Linking the Fixtures to the Controller .....	2-7
Mounting the Fixture .....	2-8
Configuring the Fixture .....	2-13
Upgrading Software .....	2-18
Troubleshooting .....	2-20

## Chapter 3 Using the Menus

Menu System Overview .....	3-2
Menu Map .....	3-3
Menu Options .....	3-10

## Chapter 4 Preset Programming

Programming Overview .....	4-2
Creating a Scene .....	4-4
Synchronizing Preset Playback .....	4-9
Capturing Presets .....	4-11

## Chapter 5 Using the Laser Aiming Device™ (LAD™)

Safety Precautions .....	5-2
--------------------------	-----

Overview .....	5-3
Controlling the Laser .....	5-5
Troubleshooting .....	5-6
Maintenance .....	5-8

## **Chapter 6 Servicing Your Fixture**

Precautions .....	6-2
Replacing Fuses .....	6-2
Replacing Wheel Components .....	6-4
Replacing the Lamp .....	6-11
Cleaning the Internal Components .....	6-15
Technobeam Laser Aiming Device™ .....	6-19

## **Appendix A DMX Protocols**

General Information .....	A-1
Technobeam® Protocol .....	A-3
Technobeam-i™ Protocol .....	A-7
MSpeed Movement Times .....	A-12
Macro Channel Assignments .....	A-15
Fixture Number to DMX Start Channel .....	A-16

## **Appendix B Factory-Installed Wheels**

Technobeam™ Wheels .....	B-1
--------------------------	-----

## **Appendix C Important Safety Information**

English Version .....	C-1
Appendice C IMPORTANT: INFORMATIONS DE SÉCURITÉ .....	C-2
Anhang C Wichtige Hinweise Für Ihre Sicherheit .....	C-3
Appendice C Importanti Informazioni Di Sicurezza .....	C-4
Apéndice C Información Importante De Seguridad .....	C-5
Vigtig Sikkerhedsinformation - DANMARK .....	C-6

## **Index**

# Table of Figures

Figure 1-1. Identifying yoke components. ....	1-8
Figure 1-2. Installing the yoke on the fixture. ....	1-9
Figure 1-3. Removing the door allows you to access the fixture's voltage selection switches, as well as wheels and optics. ....	1-11
Figure 1-4. The three voltage selection switches located next to the LED display. ....	1-11
Figure 1-5. Setting the fixture's voltage and frequency. ....	1-11
Figure 1-6. The lens tube contains the zoom lenses. ....	1-12
Figure 1-7. Squeeze the two latches on each side of the lens tube to open the cover. ....	1-12
Figure 1-8. Components of the factory-installed 11 to 17 degree lens set. ....	1-13
Figure 2-1. The initial LED menu display shows the fixture's software version. ....	2-2
Figure 2-2. Location of the three status LEDs on the fixture's access door. ....	2-3
Figure 2-3. Properly-constructed data cabling. ....	2-5
Figure 2-4. Constructing a data cable terminator. ....	2-6
Figure 2-5. Location of the DMX data in (male) and DMX data Out (female) ports on the fixture's rear panel. ....	2-7
Figure 2-6. Connecting fixtures to a controller. Make sure you terminate the last fixture in the link. ....	2-8
Figure 2-7. Use a locking washer when attaching a fixture to a truss. ....	2-10
Figure 2-8. Always use a safety cable when mounting the fixture. ....	2-11
Figure 2-9. Location of the T-handle you use to adjust the yoke position. ....	2-11
Figure 2-10. You can slide the yoke all the way back to allow the fixture to hang upside-down. ....	2-12
Figure 2-11. Menu navigation buttons. ....	2-13
Figure 2-12. This fixture has software version 3. ....	2-20
Figure 2-13. Location of the fixture's exhaust vent. ....	2-22
Figure 3-1. Technobeam navigation buttons. ....	3-2
Figure 4-1. Making sure the shutter is open. ....	4-5
Figure 4-2. A dot always appears in the LED display whenever preset playback is on. ....	4-9
Figure 4-3. When you set up fixtures for synchronized playback on a DMX 512 link, one and only one fixture must be fixture number 1 or DMX start channel 1. The last fixture on the link must be terminated. ....	4-10
Figure 5-1. The laser light exits the through the same aperture as the light beam. ....	5-4
Figure 5-2. The ideal position of the laser is no more than 2" (5 cm) directly above the center point of a perfectly round light beam. ....	5-4
Figure 5-3. Removing the access door. ....	5-6
Figure 5-4. LAD wiring connections. ....	5-7

Figure 5-5. The laser aiming device circuit board. ....	5-8
Figure 6-1. Removing the door allows you to access the fixture's voltage selection switches and fuses, as well as wheels and optics. ....	6-3
Figure 6-2. Locations of the three fuses on the circuit board.....	6-4
Figure 6-3. Location of the wheels in Technobeam. ....	6-5
Figure 6-4. Push the dichroic toward the large retaining tab to free it from the wheel tabs. ....	6-6
Figure 6-5. You can easily tell which side of a dichroic is coated by placing a pen or other object near the surface; on the coated side, the reflection from the object will appear to touch the object. ....	6-6
Figure 6-6. The rotating litho wheel and rotating effects wheel have built-in plastic tabs that hold the spring in place. ....	6-7
Figure 6-7. To replace a static litho in the rotating litho wheel, gently separate the wheel and reach behind the wheel to push the litho out. ....	6-8
Figure 6-8. Location of the retaining tabs and slot that secure the static litho in the rotating litho wheel. ....	6-9
Figure 6-9. The gap between the two halves of the rotating litho wheel must be uniform. ....	6-9
Figure 6-10. An aperture ring, if required, must be placed on top of the litho/effect and under the spring.....	6-10
Figure 6-11. When you replace a rotating litho or rotating effect, make sure the tip of the spring is fully seated under the wheel tabs; it cannot protrude from under the tabs.....	6-10
Figure 6-12. Replacing a custom multi-colored litho in the metal holder..	6-11
Figure 6-13. Loosening the lamp assembly screws gives you access to the fixture lamp. ....	6-12
Figure 6-14. Removing the lamp assembly from the fixture. ....	6-12
Figure 6-15. Pull straight up on the lamp, grasping its ceramic base, to remove it from the assembly.....	6-13
Figure 6-16. Hold the lamp by its ceramic base and gently press the two base pins into the socket.....	6-13
Figure 6-17. You can look at the lamp label text to make sure the lamp plate is oriented correctly; incorrect orientation can result in damage to the fixture and the lamp. ....	6-14
Figure 6-18. Lamp optimization screws.....	6-15
Figure 6-19. Opening the fixture's access door. ....	6-16
Figure 6-20. Location of the anti-reflective glass, lenses and hot mirror...	6-17
Figure 6-21. The lens tube contains the zoom lenses. ....	6-17
Figure 6-22. Clean both sides of the hot mirror glass. ....	6-18
Figure 6-23. The ideal position of the laser is no more than 2" (5 cm) directly above the center of a perfectly round light beam....	6-19
Figure 6-24. High-voltage component location.....	6-20
Figure 6-25. Orient the fixture directly facing a wall no less than 10 ft. (3 m) away.....	6-21

Figure 6-26. Locating the center point of the projected light beam. The laser should be no more than 2" (5 cm) above the center. ....	6-24
Figure 6-27. The laser aiming device assembly has three screws that can be used to adjust the position of the laser.....	6-25
Figure B-1. Factory configuration of the Technobeam rotating litho wheel. .	B-1
Figure B-2. Factory configuration of the Technobeam color wheel. ....	B-2
Figure B-3. Factory configuration of the Technobeam rotating effects wheel.....	B-2

## Table of Tables

Table 1-1. Optional Accessories .....	1-5
Table 1-2. Beam Angles for Factory-Installed 11 to 17 Degree Lens Set .....	1-14
Table 1-3. Beam Angles for Optional 8 to 12 Degree Narrow Angle Lens Set .....	1-14
Table 2-1. Status LEDs .....	2-3
Table 2-2. Example: Determining the DMX Start Channel .....	2-16
Table 2-3. Example: Determining the Unique Fixture Number .....	2-17
Table 2-4. Example of Wasted DMX Channels .....	2-18
Table 3-1. Technobeam Menu Map .....	3-3
Table 6-1. Replacement Fuses .....	6-2
Table 6-2. Fuse Failure Symptoms .....	6-3
Table A-1. Technobeam DMX Protocol .....	A-3
Table A-2. Technobeam-i DMX Protocol .....	A-8
Table A-3. MSpeed Movement Times .....	A-13
Table A-4. Macro DMX Channel Assignments .....	A-15
Table A-5. Fixture Number to DMX Start Channel Conversion .....	A-16



# Introduction

Congratulations on your purchase of the Technobeam® automated luminaire. Since 1989, High End Systems® has enjoyed a reputation within the professional lighting industry as the premier manufacturer of intelligent lighting. This tradition of excellence is carried forward with Technobeam.

For the first time ever, stunning light output and extended lamp life are combined with superior photolithographic image projection quality in a compact package destined to revolutionize intelligent lighting in retail, themed environment, entertainment, architectural and other applications.

Technobeam has a factory-installed standard lens set with 11° to 17° beam angle, and an optional 8° to 12° narrow angle lens set. The fixture's remote focus provides razor sharp beam or image projection at various trim heights and throw distances. As with all High End Systems intelligent luminaires, Technobeam includes remotely-controllable and programmable full optical dimming, fade-to-black, and variable-speed strobe effects.

## Features

---

### Programming

- On-board sixteen scene memory for controller-free, stand-alone operation.
- High-resolution DMX 512 control, with optional reduced-channel protocol.
- DMX 512 protocol and onboard programming each feature 28 fixture-specific *macros* (unique combinations of constructs) to simplify programming.

### Optics and Effects

- Two-piece clear anodized elliptical/spherical reflector system (patent pending) delivers a remarkable (>50%) gain in light output compared with the elliptical reflectors used in other fixtures of this type.
- Factory-installed 11° to 17° lens set.
- Optional 8° to 12° narrow angle lens set.

- Mirror head providing 180° pan, 95° tilt.
- 12 saturated dichroic colors—including a 3000K color correction filter—plus open position.
- Rotating 8-position LithoPatterns® wheel features 7 replaceable positions plus open.
- Optional static litho in each of the 7 replaceable rotating litho positions for layered moire and multi-focus effects.
- Effects wheel features five replaceable, rotating effects—including frost, lenticular, and hammered.
- Optional open slot at one or more effects positions.
- Improved flat field beam performance.

**Note** All beam angles are accurate to  $\pm 1^\circ$ .

### **Construction**

- Lens tube, wheel gears, front and rear bezels manufactured from lightweight, rugged, engineering thermopolymer.
- Tough powder-coated aluminum side panels.
- Molded handles for easy transportation, lifting and mounting.

### **Lamp**

High End Systems recommends you use an M series, GY9.5 base, 250-watt metal halide arc lamp (such as the MSD 250-2) which provides 6500K stable operation and extended lamp life.

The lamp can be remotely switched off, conserving approximately 70% of the power to the unit compared to the lamp being on.

### **Other features**

- Remote focus
- Full dimming and fade-to-black
- Variable-speed strobe
- Yoke assembly features sliding track for mounting flexibility
- Available as standard in black or white
- Power factor correction
- Self-adjusting fan speed to compensate for ambient temperature conditions

# Symbols

---

This section explains symbols used in this manual:



Appears adjacent to Caution messages. A Caution is an advisory provided to protect the equipment; failure to heed a Caution message could result in damage to the equipment and possibly injury to persons.



Appears adjacent to Electrical Shock hazards. Failure to heed these messages could result in injury to persons.



Appears adjacent to Explosion warnings. Failure to heed these messages could result in injury to persons.



Indicates that eye and hand protection is required. Failure to do so could result in injury to persons.

# Document Conventions

---

Convention	Meaning
<key>	Menu keys are indicated between braces. For example, the <Enter> key on the fixture's key pad.
<b>BOLD</b>	<b>BOLD</b> type is used to indicate selections you make in the menu system.

# Contacting High End Systems

---

<b>U.S. and the Americas</b>	<b>Sales:</b>
	High End Systems, Inc. 2105 Gracy Farms Lane Austin, TX 78758
	voice: (512) 836-2242
	FAX: (512) 837-5290
	<b>Customer Service:</b>
	High End Systems, Inc. 2105 Gracy Farms Lane Austin, TX 78758
	voice: (800) 890-8989
	24-hour FAX: (512) 834-9195
	24-hour voice mail: (512) 837-3063
	or (800) 890-8989
<b>West Coast:</b>	
High End Systems, Inc. 8200 Haskell Avenue Van Nuys, CA 91406	
voice: (818) 947-0550	
FAX: (818) 908-8975	
<b>Singapore</b>	High End Systems, Singapore PTE. LTd. 1 Tannery Road 06-05 Cencon 1 Singapore 1334
	voice: +65 742 8266
	FAX: +65 743 9322
<b>Europe</b>	High End Systems Europe LTD. 53 Northfield Road London W13
	voice: +44 20.8579.5665
	fax: +44 20.8579.8469
<b>World Wide Web</b>	<a href="http://www.highend.com">http://www.highend.com</a>

# Chapter 1

## Preparing to Install Your Fixture

Specifications .....	1-2
Model Numbers .....	1-2
Dimensions (with yoke and handles) .....	1-2
Weight (including yoke) .....	1-2
Electrical Specifications .....	1-2
Technobeam Laser Aiming Device™ (LAD™) .....	1-2
LAD Safety Standards .....	1-3
Important Power Cord Information - U.K. Only .....	1-3
Vigtig Sikkerhedsinformation - DANMARK .....	1-3
Dichroic, Litho and Effects Specifications .....	1-4
Safety Standards .....	1-4
Electromagnetic Standards .....	1-4
Environmental Specifications .....	1-5
DMX Data Cabling .....	1-5
Controllers .....	1-5
Optional Accessories .....	1-5
Unpacking the Fixture .....	1-6
Save the Shipping Materials .....	1-6
Inspecting the Contents .....	1-7
Installing the Power Cord Cap .....	1-7
Important Power Cord Cap Information - U.K. Only .....	1-7
VIGTIG FIKKER HEDS INFORMATION - DANMARK .....	1-8
Installing the Yoke .....	1-8
Setting the Fixture Voltage .....	1-10
Setting the Beam Angle .....	1-12

# Specifications

---

## Model Numbers

<b>Model:</b>	Technobeam
<b>Manufacturer:</b>	High End Systems, Inc.®
<b>Distributor:</b>	High End Systems, Inc. 2105 Gracy Farms Lane Austin, Texas, 78758 USA

## Dimensions (with yoke and handles)

in: 34 L x 13 H x 16 W  
cm: 86 L x 33 H x 41 W

**Note** The height of the fixture without the yoke is 9.6 in. (24 cm).

## Weight (including yoke)

41 lbs (19 kg)

## Electrical Specifications

- **Voltages:** 100/120/230 V; 50 Hz; 3.75/3.13/1.6 A  
100/120/208 V; 60 Hz; 3.75/3.13/1.8 A
- **Rated power:** 375 W
- **Power factor, 120V, 60 Hz:** 0.96
- **Power factor, 230V, 50 Hz:** 0.90
- **Fuses:**
  - **F1**—125V, 4.0A, Fast Blow Only (5mm x 20mm)
  - **F2**—250V, 2.5A, Fast Blow Only (5mm x 20mm)
  - **F3**—250V, 6.3A, Slow Blow Only (5mm x 20mm)



**Class I equipment - This equipment must be earthed.**

## Technobeam Laser Aiming Device™ (LAD™)



The specifications below apply *only* to Technobeam fixtures that have the Laser Aiming Device (LAD) installed.

- Class 3a laser product
- Beam divergence angle: 0.2mRad to 0.3mRad

- Maximum output (continuous): 5mW at 630-650nm
- Maximum output (pulsed): <2.5mW
- Pulse modulation: 4.25Hz to 255Hz @ 50% duty cycle
- Pulse duration: 1.96ms to 117ms
- Pulse energy: 9.8μJ to 585μJ

## LAD Safety Standards

- EN60825-1, 1994
- 21 CFR 1040

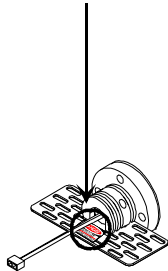

Laser aiming device assembly  
(inside fixture)

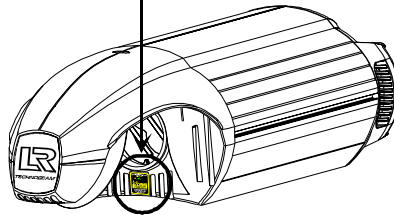

## Important Power Cord Information - U.K. Only

**IMPORTANT** The cores in the mains lead are colored in accordance with the following code:

- **green and yellow:** earth
- **blue:** neutral
- **brown:** live



**This equipment must be earthed.**

## Vigtig Sikkerhedsinformation - DANMARK

Advarsel: Beskyttelse mod elektrisk chock.

Vigtigt!

Lederen med gul/groen isolation maa kun tilsluttes en klemme maerket



eller



# Dichroic, Litho and Effects Specifications

You can install any High End Systems-manufactured solid dichroic filters, effects LithoPatterns lithos, ArtGlass, or Fusion Fire<sup>®</sup>—as long as they were manufactured for use with Technobeam and not another fixture; otherwise, the dichroics, lithos or effects might not fit in the wheels properly.

You can also install gobos or lithos from other manufacturers as long as they adhere to the following specifications:

## Dichroics

- Diameter: 1.125"  $\pm$  0.010" (28.5 mm  $\pm$  0.25 mm)
- Thickness: 0.069"  $\pm$  0.010" (1.8 mm  $\pm$  0.25 mm)

## Lithos

- Diameter/image area: 0.996"/0.860"  $\pm$  0.005" (25 mm/22 mm  $\pm$  0.13 mm)
- Maximum thickness (rotating litho only): 0.105"  $\pm$  0.005" (2.7 mm  $\pm$  0.13 mm)
- Thickness (static litho only): 0.069"  $\pm$  0.010" (1.8 mm  $\pm$  0.25 mm)

## Rotating effects wheel

- Diameter/image area: 1.43"/1.04"  $\pm$  0.010" (36 mm/26 mm  $\pm$  0.25 mm)
- Maximum thickness: 0.175"  $\pm$  0.010" (4.4 mm  $\pm$  0.25 mm)

# Safety Standards

Technobeam conforms to:

- EN 60598-1 : 1993
- EN 60598-2-17 : 1989  
A1-A3 : 1993
- ANSI/UL-1572
- CAN/CSA C22.2 No. 9

# Electromagnetic Standards

- EN 55022, Class A ITE
- IEC 801-2, 1991 Level 2 (4/8 kV)
- IEC 801-3, Draft 5 Level 2 (3 V/m)
- IEC 801-4, 1988 Level 2 (1 kV/0.5 kV)



ETL Listed  
Conforms to  
67501 ANSI/UL-1572  
Certified to CAN/CSA  
C22.2 No. 9





## Environmental Specifications

	Maximum ambient temperature ( $T_a$ ):	50° C (122° F)
	Maximum exterior surface temperature:	70° C (158° F)
1m	Minimum distance to flammable objects:	1.0 m (3.28 ft)
	Minimum distance to lighted object:	1.0 m (3.28 ft)

## DMX Data Cabling

- **DMX data cables:** Belden® 9841 or equivalent (meets specifications for EIA RS-485 applications) with characteristics listed below:
  - 2-conductor, twisted pair plus a shield
  - maximum capacitance between conductors - 30 pF/ft.
  - maximum capacitance between conductor & shield - 55 pF/ft.
  - maximum resistance of 20  $\Omega$ /1000 ft.
  - nominal impedance 100–140  $\Omega$
  - 22–24 AWG with insulation having a dielectric rating of 300 volts or higher
- **DMX data connectors:** 3-pin male and female XLR connectors
- **DMX data terminators:** Male XLR connector with 120 ohm terminator between pins 2 and 3 (see Figure 2-4 on page 2-6)

## Controllers

Technobeam may be controlled with any of the following:

- The WholeHog III® lighting console
- The Hog PC controller
- The Technobeam LCD controller
- Another DMX 512-compatible controller

## Optional Accessories

Table 1-1 below shows the optional accessories for Technobeam, available from your High End Systems® dealer/distributor:

Table 1-1. *Optional Accessories*

Name	Part Number
Optional lens sets	Call*
Replacement MSD 250-2 lamp	Call*
Custom color wheel dichroic filters	Call*

Table 1-1. Optional Accessories

Name	Part Number
LithoPatterns	Call*
Effects	Call*
Technobeam LCD controller	29020001
Laser Aiming Device for Technobeam only <sup>†</sup>	29060002
Hog PC lighting controller	Call*
Whole Hog III lighting console	Call*
Heavy duty 3-pin XLR cable (10')	55050005
Heavy duty 3-pin XLR cable (25')	55050006
Heavy duty 3-pin XLR cable (50')	55050007
Heavy duty 3-pin XLR cable (100')	55050008
Deluxe C-clamp	55000004
Galvanized safety cable	12040001
Lightwave Research Upload Dongle	26040002

<sup>†</sup> - You must obtain the Laser Aiming Device from High End Systems Customer Service; see "Contacting High End Systems" on page Intro-4.

**Call\*** - Contact either your High End Systems dealer/distributor, High End Systems Sales, or the High End Systems World Wide Web site.

## Unpacking the Fixture

Unpack the Technobeam box and verify that the contents arrived complete and without any damage.

## Save the Shipping Materials



*Do not discard* the shipping carton and packing materials. The carton and packing materials are specifically designed to protect the product during transport.

High End Systems, Inc. assumes no responsibility for products damaged during transport. Therefore, you should return a product for repair in its original shipping carton and packing materials.

**Note** Before sending anything to the factory, call your HES dealer/distributor for a Return Material Authorization (RMA) number. The factory cannot accept any goods shipped without an RMA number.

## ***Inspecting the Contents***

Carefully unpack the carton and inspect the contents for damage. If any items in the list below are missing or damaged you must notify both the shipping agent and your sales agent immediately.

- One Technobeam fixture.
- Separate yoke packaging: one yoke, two yoke slide bezels, two allen screws, two T-handles.

## ***Installing the Power Cord Cap***

---

**IMPORTANT** The cores in the mains lead are colored in accordance with the following code:

- **green and yellow:** earth
- **blue:** neutral
- **brown:** live

In some cases, you must obtain and install a power cord cap before you can connect your fixture to a power outlet. The type of power cord cap you must obtain depends on the location in which you will use Technobeam; different locations (even within the same country) might have different power cord cap requirements.

**Note** Because of the wide variety of power cord caps used worldwide, High End Systems, Inc. cannot make specific recommendations for the particular power cord cap you should use. Contact a local authority if you are unsure which type of power cord cap you need.

## ***Important Power Cord Cap Information - U.K. Only***

Since the colors of the cores in the mains lead of this equipment may not correspond with the colored markings identifying the terminals in your plug, proceed as follows:

- The core which is colored green and yellow must be connected to the terminal in the plug which is marked with the letter "E" or by the earth symbol  $\oplus$ , or colored green or green and yellow.
- The core which is colored blue must be connected to the terminal which is marked with the letter "N" or colored black.

- The core which is colored brown must be connected to the terminal which is marked with the letter “L” or colored red.



**Class 1 equipment: This equipment must be earthed.**

## **VIGTIG FIKKER HEDS INFORMATION - DANMARK**

**Advarsel:** Beskyttelse mod elektrisk chock.

Vigtigt!

Lederne med gul/groen isolation maa kun tilsluttes en klemme maerket

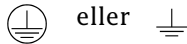

## **Installing the Yoke**

**You will need:** *one 1/4" allen wrench*

This section explains how to install the moving-track yoke. You can adjust the yoke however you want to distribute the weight of the fixture. You can even slide the yoke all the way to the end of the fixture to hang it straight down.

1. Identify the components shown in Figure 1-1:

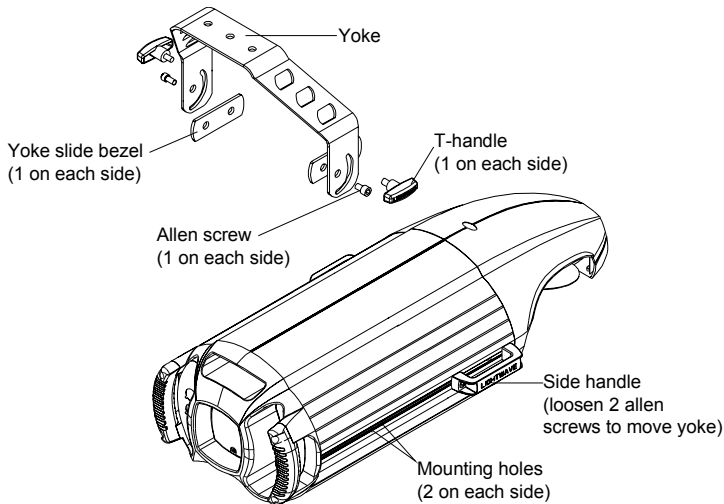

*Figure 1-1. Identifying yoke components.*

2. Use a 1/4" allen wrench to attach one allen screw to each side of the fixture (but do not fully tighten it), as shown in Figure 1-2. *Make sure you place a yoke slide bezel between the yoke and each side of the fixture.*

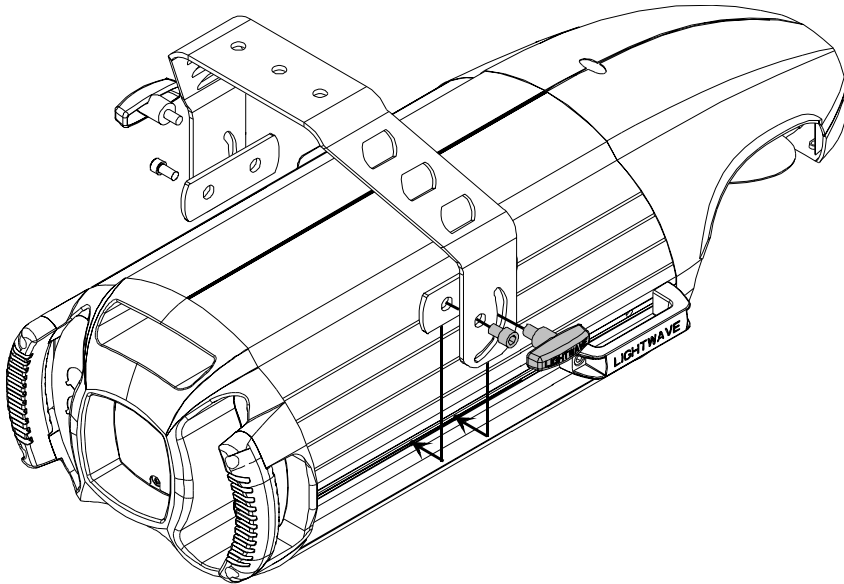

*Figure 1-2. Installing the yoke on the fixture.*

3. Manually screw one T-handle into each side of the fixture. Do not fully tighten the T-handles.
4. If you want to reposition the yoke, use a 1/4" allen wrench to loosen the allen screws on the side handles shown in Figure 1-1 on page 1-8.
5. After loosening the side handle allen screws, slide the yoke to the desired position. If you want to hang the fixture straight down, see the section titled "Hanging the Fixture Straight Down" on page 2-12 now.
6. Make sure the yoke is even (i.e., the same distance from the rear of the fixture on both sides).
7. Securely tighten the four side handle allen screws (two on each side).
8. Tilt the fixture to the desired angle, then securely tighten the other allen screws and T-handle.

# Setting the Fixture Voltage

---

Technobeam is shipped from the factory set for 230V, 50Hz and offer the following switch-selectable voltage/frequency settings:

230 V, 50 Hz	208 V, 60 Hz
100 V, 50 Hz	100 V, 60 Hz
120 V, 50 Hz	120 V, 60 Hz

The recommended fuse F3 for all voltages and frequencies is:

**F3 - 250V, 6.3A, Slow Blow Only.**



## WARNINGS

**(1) Check the voltage setting before proceeding with equipment setup!**

**(2) The information in this section is intended to assist qualified service personnel because this fixture is to be serviced by qualified service personnel *only*.**

**(3) Disconnect power before re-lamping or servicing.**

**(4) Replace fuses with specified type and rating only.**

1. Make sure the fixture is disconnected from the power outlet before proceeding.
2. Lay the fixture on its back and locate the door retaining screw, as shown in Figure 1-3. Loosen the screw and remove the access door.

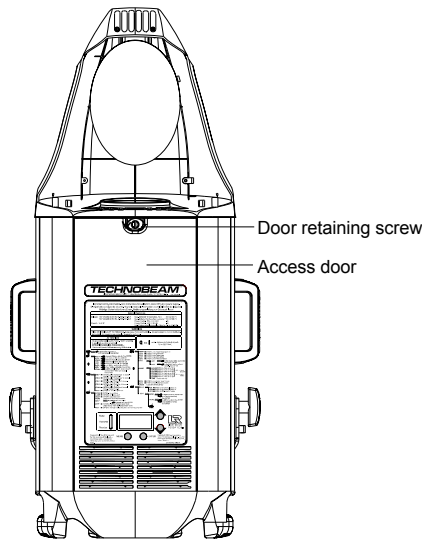

Figure 1-3. Removing the door allows you to access the fixture's voltage selection switches, as well as wheels and optics.

3. Locate the three switch blocks—labeled SW1, SW2 and SW3—by the LED display, as shown in Figure 1-4:

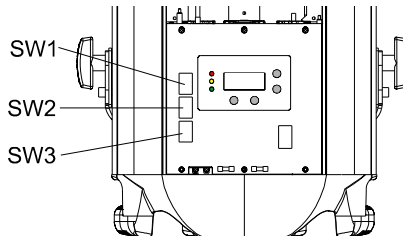

Figure 1-4. The three voltage selection switches located next to the LED display.

4. Choose a voltage/frequency setting as shown in Figure 1-5:

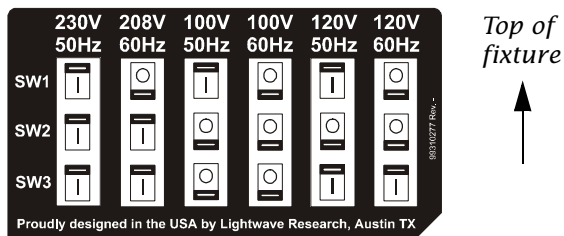

Figure 1-5. Setting the fixture's voltage and frequency.

5. Replace the access door, unless you want to install the optional narrow lens set or set the beam angle as shown in the next section.

# Setting the Beam Angle

This section explains how to set the fixture's beam angle. (It also shows how to install the optional 8 to 12 degree narrow angle lens set.) You can change the beam angle, for example, if you are having trouble focusing precisely on a very detailed image.

Selecting a larger beam angle results in a larger-diameter image, but can also result in some loss of image resolution and light intensity.

**Note** All beam angles are accurate to  $\pm 1^\circ$ .

1. Unplug the fixture and remove the access door shown in Figure 1-3 on page 1-11 if you have not done so already.
2. Lay the fixture on its back and locate the lens tube as shown in Figure 1-6.

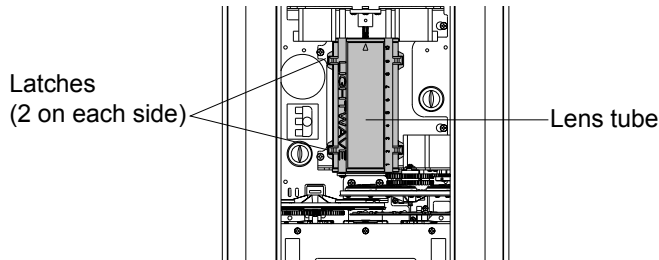

Figure 1-6. The lens tube contains the zoom lenses.

3. The lens tube cover has two latches on each side that secure it in place; see Figure 1-7. Squeeze the latches together to remove the lens tube cover.

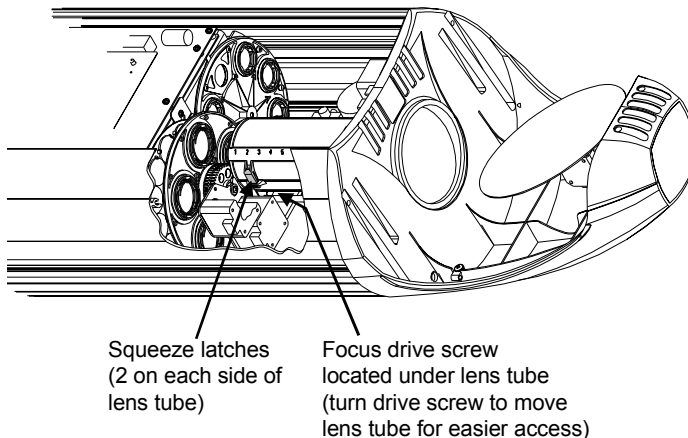

Figure 1-7. Squeeze the two latches on each side of the lens tube to open the cover.



**Hint**

If the latches are difficult to access, reach under the lens tube and manually turn the focus drive screw to move the lens tube toward the rotating effects wheel.

4. The factory-installed 11 to 17 degree lens set is shown Figure 1-8:

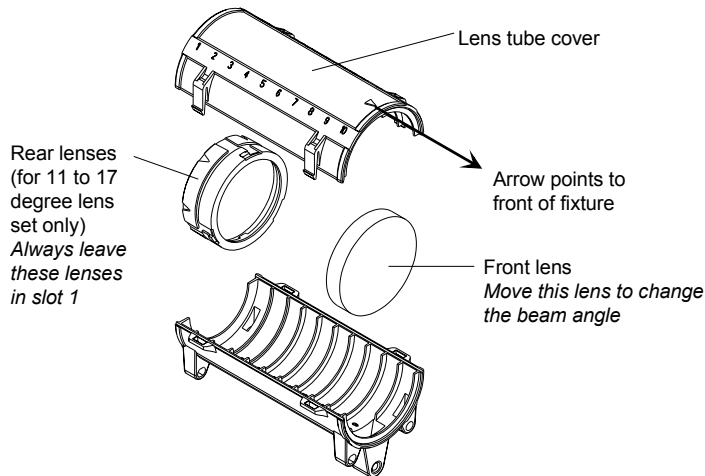

Figure 1-8. Components of the factory-installed 11 to 17 degree lens set.

5. This step applies to the optional 8 to 12 degree narrow angle lens set only.
- Remove all lenses shown in Figure 1-8 and put them in a safe place where they will not get scratched.
  - Use Table 1-3 on page 1-14 to install the two lenses in the 8 to 12 degree narrow angle lens set. The name and orientation of each lens is printed on the side of the lens. The arrow printed on each lens must point *toward the aperture* (i.e., away from the lamp).
6. Lens positions in the lens tube are numbered from 1 to 10, both on the lens tube cover and on the bottom portion of the lens tube. Use those numbers in either Table 1-2 on page 1-14 or Table 1-3 on page 1-14 to move the lenses to correspond with the desired beam angle. The arrow printed on the lens must point toward the front of the fixture (i.e., away from the lamp).

**Caution**

**Handle the lenses by the edge only. Fingerprints can result in lower image quality. Use only a soft, lint-free cotton cloth to clean lenses. Use a mild glass cleaning solution if necessary to clean built-up dust or dirt.**

*Table 1-2. Beam Angles for Factory-Installed 11 to 17 Degree Lens Set*

Lamp (arrow points away from)

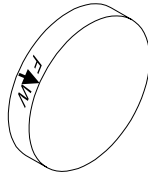

Aperture (arrow points toward)

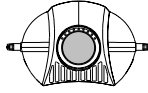

One of the following will be printed on each lens:

- F ↑ W Front lens, factory-installed lens set
- R ↑ W Rear lens, factory-installed lens set
- F ↑ N Front lens, optional narrow angle lens set
- R ↑ N Rear lens, optional narrow angle lens set

Beam Angle	Front Lens Position*
11.5°	10
13.5°	8
15°	6
16.5°	4
17.5°	3
* - For the 11 to 17 degree lens set, the rear lenses must always be placed in slot 1 (see Figure 1-8 on page 1-13).	

*Table 1-3. Beam Angles for Optional 8 to 12 Degree Narrow Angle Lens Set*

Beam Angle	Rear Lens Position	Front Lens Position
8°	1	10
8.6°	2	10
9.1°	2	9
9.7°	2	8
10.3°	3	8
10.8°	3	7
11.4°	3	6
12°	3	5

7. When you are finished, replace the lens tube cover, making sure to point the arrow on the cover toward the front of the fixture.

# Chapter 2

## Setting Up Your Fixture

Powering On the Fixture .....	2-2
Homing the Fixture .....	2-2
LED Display .....	2-2
Status LEDs .....	2-3
Overview of Controller Operation .....	2-4
What is DMX 512 Protocol? .....	2-4
What Kind of Cabling Should You Use? .....	2-4
Constructing Cabling .....	2-5
Terminators .....	2-5
Setting up the Link .....	2-6
Linking the Fixtures to the Controller .....	2-7
Mounting the Fixture .....	2-8
Standing the Fixture on its End Handles .....	2-9
Mounting the Fixture on a Truss or Other Support System .....	2-9
Hanging the Fixture Straight Down .....	2-12
Configuring the Fixture .....	2-13
Fixture Types .....	2-13
Selecting a Control Method .....	2-14
DMX Start Channel Control Method .....	2-14
Fixture Number Control Method .....	2-14
Assigning a Fixture Address .....	2-15
Channel Range .....	2-15
Determining the Unique DMX Start Channel .....	2-16
Determining the Unique Fixture Number .....	2-17
Wasted DMX Channels .....	2-17
Upgrading Software .....	2-18
Crossloading Software .....	2-19
Troubleshooting .....	2-20
Troubleshooting DMX Data .....	2-24
Menu Error Messages .....	2-25
Addr Lost .....	2-25
Boot Diff .....	2-25
EMEM Ack .....	2-26
EMEM [message] .....	2-26
Erse Flsh .....	2-26
ID Lost .....	2-26
Lamp .....	2-27
Link Busy .....	2-27
Link Empty .....	2-27
Over Temp .....	2-28
PRST Lost .....	2-28
PGRM Time .....	2-28
Shut Down .....	2-28

# Powering On the Fixture

---

Do all of the following before powering on the fixture:

1. Select the correct voltage and frequency settings for the power outlet you will be using. See the section titled “Setting the Fixture Voltage” on page 1-10.
2. Install the appropriate power cord cap as described in the section titled “Installing the Power Cord Cap” on page 1-7.
3. Replace the access door shown in Figure 2-2 on page 2-3.

## Homing the Fixture

Connect the fixture to an appropriately-rated power outlet; there is no power switch. You will hear the sounds of the motors and gears as they home. *This is normal.*

## LED Display

When the fixture has finished homing, the LED display should show the fixture’s software version, similar to Figure 2-1:

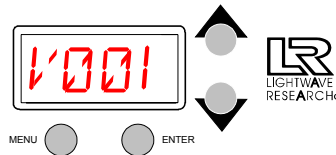

Figure 2-1. The initial LED menu display shows the fixture’s software version.

**Note** The LED display will alternate between the version number (shown above) and the fixture number or DMX start channel unless an error occurs during start-up.

If the fixture fails to home, or if the menu displays an error message, see the section titled “Troubleshooting” on page 2-20 now.

# Status LEDs

Technobeam fixtures have three status LEDs located on the access door, as shown in Figure 2-2:

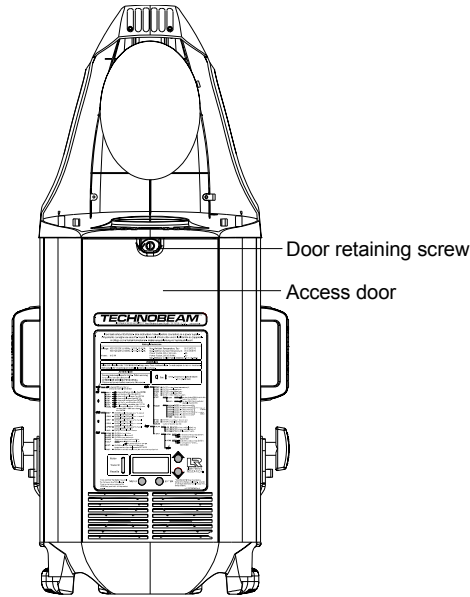

Figure 2-2. Location of the three status LEDs on the fixture's access door.

Table 2-1 describes the three status LEDs:

Table 2-1. Status LEDs

LED name	State	Problem Indication?	Description
Motor	solid red	No	The motors are receiving adequate voltage.
	OFF	Yes	Fuse or power failure. See below.
Transmit	OFF	Not necessarily*	No data is being transmitted.
	flickering yellow	No	A software crossload is taking place.
	solid yellow	Yes <sup>†</sup>	Software or hardware failure.
Receive	OFF	Not necessarily*	No data is being received.
	flickering green	No	Fixture is receiving data.

If the LED states indicate a problem, see the section titled "Troubleshooting" on page 2-20.

\* - The Receive LED will not be ON unless the fixture is connected to a DMX 512 link with a working controller. If you have already connected

the fixture to a controller and are sending DMX 512 commands to the fixture, and the Receive LED is OFF, see the section titled “Troubleshooting” on page 2-20.

† - Unless this fixture is crossloading, the yellow Transmit LED should never be ON solid. (The Transmit LED will flicker yellow if you have enabled preset playback *and* the fixture is set for either fixture number 1 or DMX start channel 1. This is due to preset playback synchronization, as described in “Synchronizing Preset Playback” on page 4-9. Try unplugging the fixture, waiting a few minutes, then plugging it back in. If the Transmit LED continues to be ON, contact High End Systems Customer Service in one of the ways shown in the section titled “Contacting High End Systems” on page Intro-4.

More information about crossloading software is shown in the section titled “Upgrading Software” on page 2-18.

## ***Overview of Controller Operation***

---

In order to coordinate the playback of multiple Technobeam fixtures from a central location, you need to connect the fixtures to a DMX 512-compatible controller using XLR data-grade cabling.

### ***What is DMX 512 Protocol?***

DMX 512 is an industry-standard protocol for controlling lighting fixtures and other devices (such as lasers and hazers). Developed by the United States Institute of Theatre Technology (USITT), DMX 512 is supported by leading entertainment industry equipment manufacturers.

DMX 512 (*D* for *digital*, *MX* for *multiplex* and *512* is the number of channels per link) is a reliable, efficient and well-understood control protocol. Its strength lies in its ability to control virtually any mix of DMX-compatible devices on the same link using a DMX-compatible controller.

### ***What Kind of Cabling Should You Use?***

There are two main types of cabling you can use: microphone cable and data-grade cable. Although pin-compatible microphone cable is suitable for small-scale designs, data cable is recommended, especially for longer cable runs. Data cable is designed to carry a higher-quality signal with less susceptibility to electromagnetic interference.

The cable you use should have the characteristics listed below:

- 2-conductor twisted pair plus a shield
- maximum capacitance between conductors - 30 pF/ft.

- maximum capacitance between conductor and shield - 55 pF/ft.
- maximum resistance of 20  $\Omega$ /1000 ft.
- nominal impedance 100–140  $\Omega$
- 22–24 AWG with insulation having a dielectric rating of 300 volts or higher

For example, Belden<sup>®</sup> 9841 data-grade cabling meets specifications for EIA RS-485 applications and is highly recommended (or its equivalent) for use with Technobeam.

## Constructing Cabling

If you need to construct cabling, you must use a shielded, two-conductor cable with a male 3-pin XLR connector on one end and a female 3-pin XLR connector on the other end. Pin 1 is the common (cable shield), pin 2 is the data complement (negative), and pin 3 is the data true (positive).

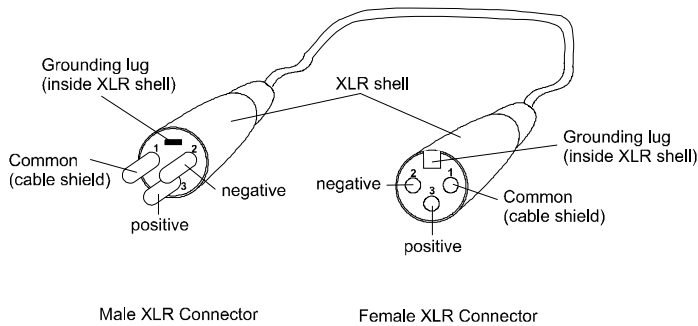

Figure 2-3. Properly-constructed data cabling.

You should test each cable with a voltage/ohm meter (VOM) to verify correct polarity and to make sure that the negative and positive pins are not grounded or shorted to the shield or to each other. Also, make sure that pin 1 is shielded.



### Caution

**Do not connect anything to the ground lug on the XLR connectors. Do not connect or allow contact between the common (cable shield) and the fixture's chassis ground. Grounding the common could cause a ground loop and/or erratic behavior.**

## Terminators

The last device on each link must have a 120 ohm, 1/4 watt (minimum)

terminator attached to its Data Out connector.

You can construct terminators by following the instructions below:

1. Obtain a male XLR connector.
2. Disassemble the connector.
3. Solder a 120 ohm resistor, minimum of 1/4 watt, between pins 2 and 3.
4. Reassemble the connector.
5. Install the terminator in the Data Out port of the last device in the link.

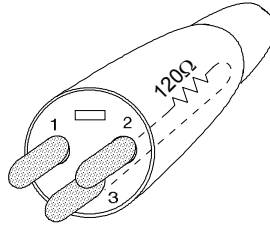

Figure 2-4. Constructing a data cable terminator.

## Setting up the Link

Follow the guidelines below when setting up the DMX link:

1. Do not allow the DMX channel ranges (boundaries) used by two different devices on the link to overlap. Overlapping boundaries can disable one or both devices. See Chapter 3 for more information about channel boundaries for Technobeam. Consult the documentation provided with the other devices for their DMX channel ranges.
2. You can assign two fixtures of the same type (for example, two Technobeam fixtures both set to full protocol) to the same DMX channel range if you want both fixtures to respond to control commands in exactly the same way.
3. *Software uploads (updates):* You must remove or bypass all controllers, non-High End Systems fixtures, optoisolators and serial data distributors on the link if you want to perform software uploads or crossloads as described in the section titled “Upgrading Software” on page 2-18.

Dataflash<sup>®</sup> AF1000 xenon strobes, Intellabeam<sup>®</sup> automated luminaires, and Emulator<sup>®</sup> laser simulators will stop software uploads to Technobeam fixtures farther down the link. Make sure you put all of the Intellabeam fixtures, Emulator fixtures and AF1000 fixtures *after* all of the Technobeam fixtures.

4. As long as you observe all of the rules above, you can use whatever DMX channels and cabling scheme you want. You do not, for example, have to assign the lowest DMX start channel to the fixture directly connected to the controller. Use whatever channel and cabling scheme is simplest and results in the least amount of cabling.



# Linking the Fixtures to the Controller

Starting with the controller, link fixtures using the procedure below.

1. Consult the documentation provided with the controller for the procedure to connect XLR cable to its Data Out connector.
2. Connect the female end of the XLR cable from the controller to the first fixture's male Data In connector.
3. Connect the male end of another XLR cable to the first fixture's female Data Out connector.
4. Continue connecting the Data Out connector from one fixture to the Data In connector to the next fixture until you have linked all of the Technobeam fixtures.
5. Connect other devices to the Technobeam fixtures as desired, using the instructions in the documentation provided with those devices.

Place a male 120 ohm terminator on the female Data Out connector of the last device in the link. The procedure for making a terminator can be found in the section titled "Terminators" on page 2-5.

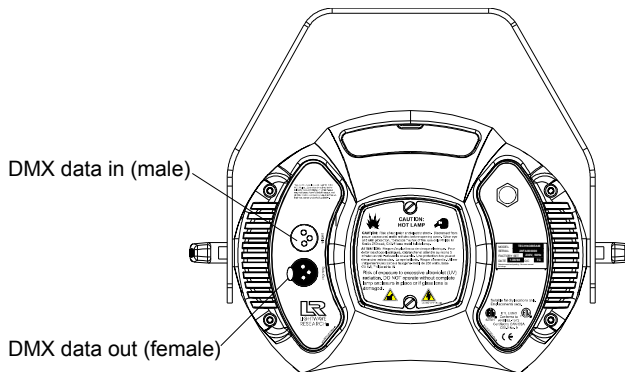

*Figure 2-5. Location of the DMX data in (male) and DMX data Out (female) ports on the fixture's rear panel.*

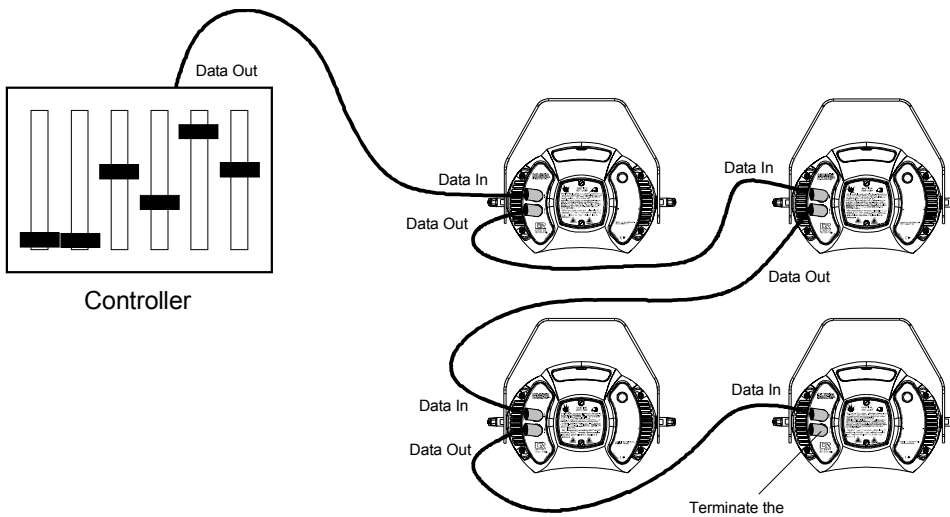

Figure 2-6. Connecting fixtures to a controller. Make sure you terminate the last fixture in the link.

## Mounting the Fixture

**You will need:**

- one 1/4" allen wrench
- clamps and safety cable as described in this section

Your fixture is designed to be mounted in any orientation: you can even hang it with its aperture pointing straight down or stand it on its end handles. However you wish to mount the fixture, you must follow the precautions and suggestions below:

- Verify the input voltage you are using matches the fixture's voltage selection switches (see the section titled "Setting the Fixture Voltage" on page 1-10).
- Heed the warnings below to guard against personal injury and damage to the fixture.



### WARNINGS

**(1) This equipment for connection to a branch circuit having a maximum overload protection of 20 A.**

**(2) Class I Equipment - This fixture must be earthed.**

**(3) Mount the fixtures and controllers in a location that is away from direct heat and protected from moisture. Do not mount on a flammable surface.**



**(4) Maintain minimum distance of 1.0 meter (3.28 feet) from combustibile materials.**

**(5) Observe minimum distance to lighted objects of 1.0 meter (3.28 feet). This means the fixture must be positioned at least 1 meter away from the object it is illuminating.**

**(6) Use a secondary safety cable when mounting this fixture.**

## ***Standing the Fixture on its End Handles***

The fixture's end handles are designed to support its weight; however, make sure you observe the following guidelines:

1. The fixture must be located away from moving objects that could strike it and cause it to become unbalanced.
2. The fixture must be mounted on a sturdy, stable surface.
3. If the surface is above floor height, make sure you use safety cables as described in the next section.

## ***Mounting the Fixture on a Truss or Other Support System***

If you are mounting the fixture on a truss or another type of support, do all of the following:

1. Verify the truss or support will handle the weight of all the devices you are mounting. Technobeam fixture weights are listed in the section titled "Weight (including yoke)" on page 1-2.
2. The use of user-supplied safety cable is strongly recommended. You must supply your own safety cable and you must verify the cable is capable of supporting the weight of the fixture as listed in the section titled "Weight (including yoke)" on page 1-2. You can order galvanized safety cables from your High End Systems dealer/distributor (see "Optional Accessories" on page 1-5).
3. You must supply your own clamps to attach the fixture to the support. Verify that the clamp(s) you use are capable of supporting the weight of the fixture as listed in the section titled "Weight (including yoke)" on

page 1-2. You can order deluxe C-clamps for a two-inch truss from your High End Systems dealer/distributor (part number 55000004). Also see the section titled “Optional Accessories” on page 1-5.

4. Make sure the fixture *cannot* be rotated all the way around (360°). Allowing the fixture to rotate 360° could loosen the clamp mounting bolts.

**Note** Because of the variety of conceivable lighting designs, you should consider the procedure below as a *suggested guideline* only. High End Systems, Inc. cannot make specific recommendations for your particular lighting design or venue.

Suggested mounting procedure:

1. Use two people to mount each fixture: one person to hold the fixture while it is being secured in place, and one person to secure the fixture to its support and to attach clamps and safety cables.
2. Always stand on a firm, stable surface when mounting a fixture to its support. The fixture should be at a height where you can comfortably work on it, and should either be resting on a stable surface or held in a stable manner. *Do not allow one person to both support and mount the fixture.*
3. Attach a suitable clamp through one of the holes on top of the yoke. If you are attaching one clamp, use the middle hole on the yoke. If you are attaching 2 clamps per fixture, attach one clamp to each of the outer holes on the yoke. *Use two locking washers per clamp when attaching the clamp to the yoke.*

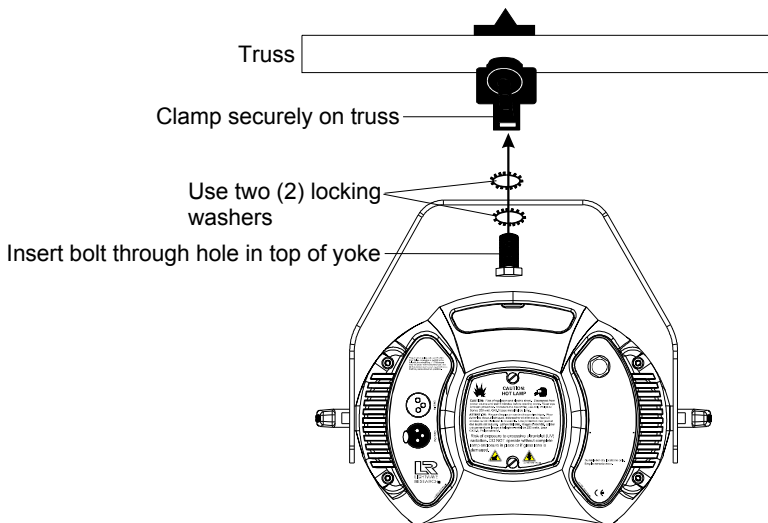
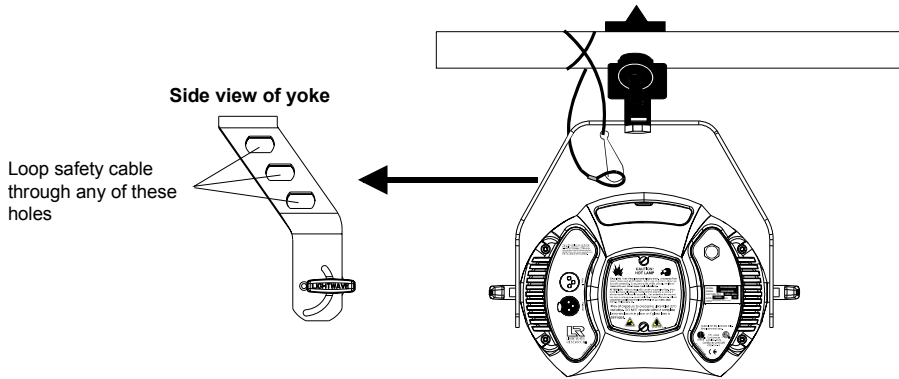

Figure 2-7. Use a locking washer when attaching a fixture to a truss.

4. Tighten the clamp(s) firmly to the yoke and to the support.
5. Loop one or more suitable safety cables around the support and the top of the yoke (see Figure 2-8).



*Figure 2-8. Always use a safety cable when mounting the fixture.*

6. Loosen the T-handles on each side of the fixture (see Figure 2-9) and orient the fixture to the desired tilt angle.
7. Tighten the T-handles to secure the fixture in the desired position.
8. When you have the fixture in the position you want, firmly tighten the T-handles shown in Figure 2-9.

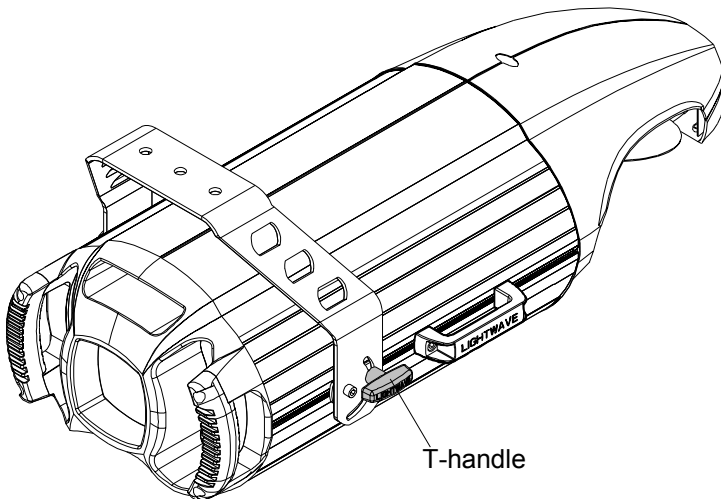

*Figure 2-9. Location of the T-handle you use to adjust the yoke position.*

## Hanging the Fixture Straight Down

You can mount Technobeam with the mirror head perpendicular to the ground for projection onto a stage. This orientation also allows you to economize truss space by hanging fixtures side by side close to each other.

You must observe all of the precautions listed on the previous pages regarding clamps and safety cables.



### Caution

**You should adjust the yoke position while the fixture is resting on a flat surface; otherwise, the fixture may be damaged if it slides backward.**

1. Use a 1/4" allen wrench to loosen the two yoke allen screws (see Figure 2-10).
2. Use a 1/4" allen wrench to loosen the four handle allen screws (two on each handle).
3. Slide the yoke to the rear of the fixture.
4. Loosen the T-handles on each side and rotate the yoke toward the rear of the fixture.

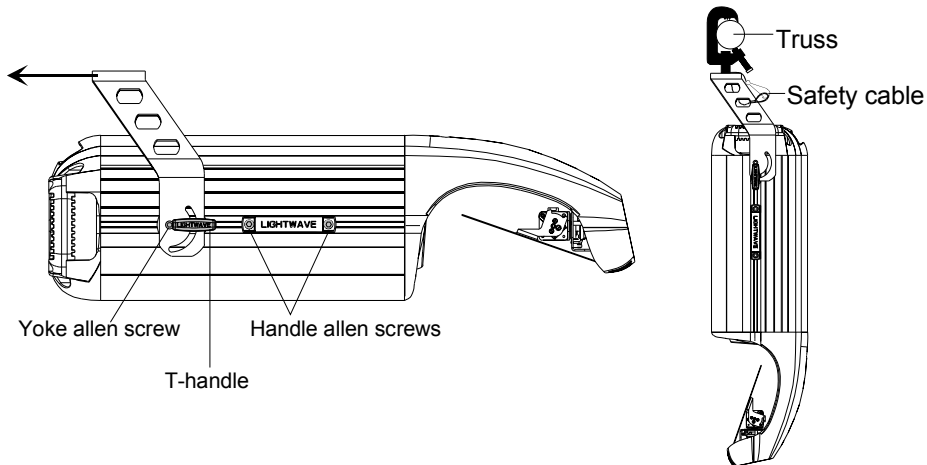

*Figure 2-10. You can slide the yoke all the way back to allow the fixture to hang upside-down.*

5. Tighten the allen screws and T-handles on both sides of the fixture, then secure the fixture to the truss using a C-clamp with a locking washer and safety cable as shown in Figure 2-10. When the fixture is mounted like you want it, securely tighten the fixture's T-handles.

# Configuring the Fixture

This section explains how to configure your fixture for operation by selecting a fixture type and control method and assigning a fixture address (either a DMX start channel or fixture number).

You must select a fixture type and control method and assign a fixture address if you want to control the fixture with a DMX 512-compatible controller. However, you can skip this section if you plan to use the fixture in stand-alone mode (without a controller) and program the fixture using preset programming, as shown in Chapter 3.

Configuring your fixture requires you to access the fixture's menu system via the alphanumeric LED display and four menu navigation buttons on the fixture's front panel (see Figure 2-11). For a detailed description of the menu system, see "Using the Menus" on page 3-1.

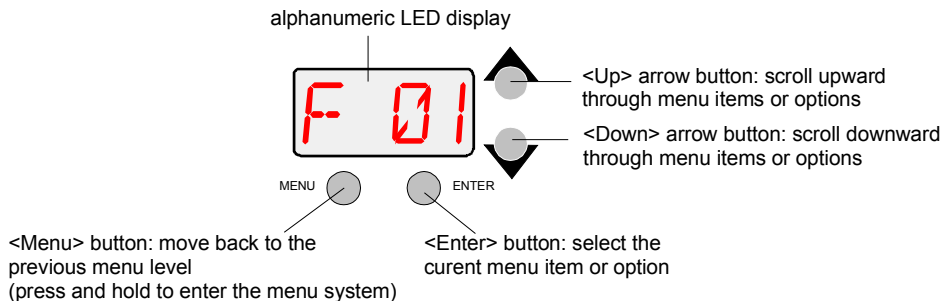

Figure 2-11. Menu navigation buttons.

## Fixture Types

Each fixture uses a fixture-specific protocol which determines the number of DMX channels the fixture will use. To change the fixture type, see "Setting the Fixture Type and Protocol (TYPE)" on page 3-15.

Available Technobeam fixture types and the number of DMX channels used per fixture are listed below:

- **T B F** - Technobeam full protocol - uses 18 DMX channels per fixture. The full protocol gives you more control over pan and tilt position and litho spin speed and is for use with fixtures that *do not* have an iris. You *must* select full protocol if you want to use the Laser Aiming Device™ (LAD™) or macros
- **T B R** - Technobeam reduced protocol - uses 14 DMX channels per fixture. You should use this protocol if you need to conserve the extra four DMX channels for other devices on the link, and your fixtures *do not* have an iris.

- **TB I** - Technobeam iris protocol - uses 18 DMX channels per fixture. This protocol should *only* be used with fixtures that have an iris.
- **TLCD** - Technopro LCD protocol - uses 18 DMX channels per fixture. This protocol should *only* be used with Technopro fixtures that are controlled with an LCD controller.

## Selecting a Control Method

You must select a control method for each fixture: either a DMX start channel (recommended) or a fixture number (for a link with fixtures that all use the same number of DMX channels).

**Note** Once you choose a control method, you should use that same control method for *all* the fixtures on a link.

### DMX Start Channel Control Method

If you plan to combine different types of devices (and/or protocols) that use different numbers of channels on one DMX link, you should use the DMX start channel control method. Using the DMX start channel method to control your fixtures allows you to assign an explicit start channel to each fixture, so no DMX channels are wasted. For more information, see “Wasted DMX Channels” on page 2-17.

To select the DMX start channel control method:

ADDR

1. Press and hold the <Menu> button until “ADDR” appears on the LED display.

SET

2. Using the <Up> and <Down> arrow buttons, scroll to the “SET” menu and press the <Enter> button to select the “SET” menu.

CHNL

3. Using the <Up> and <Down> arrow buttons, scroll to the “CHNL” menu and press the <Enter> button to select the “CHNL” menu.

DMX

4. Using the <Up> and <Down> arrow buttons, scroll to the “DMX” option and press the <Enter> button to select the “DMX” option.

**Note** You must select a control method for *each* Technobeam fixture on the link.

### Fixture Number Control Method

When you use the fixture number control method, each fixture “thinks” all other devices on the link use the *same* number of DMX channels that it uses. Therefore, using the fixture number control method is a good idea *only* if you plan to link fixtures that all use the same number of DMX channels.

For example, assign fixture numbers if you have a link that *only* controls Technobeams set to iris protocol (or other devices that use 18 DMX channels), or a link that *only* controls Technobeams set to



reduced protocol (or other devices that use 14 channels per link).

To select the fixture number control method:

ADDR

1. Press and hold the <Menu> button until “ADDR” appears on the LED display.

SET

2. Using the <Up> and <Down> arrow buttons, scroll to the “SET” menu and press the <Enter> button to select the “SET” menu.

CHNL

3. Using the <Up> and <Down> arrow buttons, scroll to the “CHNL” menu and press the <Enter> button to select the “CHNL” menu.

Addr

4. Using the <Up> and <Down> arrow buttons, scroll to the “ADDR” option and press the <Enter> button to select the “ADDR” option.

**Note** You must select a control method for *each* Technobeam fixture on the link.

## Assigning a Fixture Address

The fixture’s address identifies each fixture’s channel range on the DMX link. After you have selected a control method, you must assign a DMX start channel or fixture number to each fixture:

- If you chose the DMX start channel control method for the fixture, you must assign each fixture a DMX start channel.
- If you chose the fixture number control method, you must assign each fixture a fixture number.

You must assign a *unique* fixture address to each fixture that you want to respond *independently* to controller commands. If you want two or more fixtures to respond to controller commands in exactly the same way, all fixtures must be the same type (for example two Technobeam fixtures set to iris protocol) and must share the *entire* channel range.

## Channel Range

There are 512 available channels on each DMX link. These 512 channels are divided among *all* the devices in a particular link. The number of channels each fixture requires is called the fixture’s channel range. The size of each fixture’s channel range is determined by the fixture type (see “Fixture Types” on page 2-13).

Each Technobeam set to full, iris, or LCD protocol reserves a block of 18 contiguous channels. Each Technobeam set to reduced protocol reserves a block of 14 contiguous channels. Therefore, you can control up to 28 Technobeam fixtures set to full, iris, or LCD protocol (512 DMX channels available / 18 channels used = 28.4 fixtures per link) or up to 32 Technobeam fixtures set to reduced protocol\*.

**\*Note** Although there are enough available DMX channels to link up to 36 Technobeam fixtures in reduced protocol, you must use a DMX splitter to connect more than 32

fixtures per link. The 32 device limit complies with the EIA-485 standard. Connecting more than 32 devices per link without a DMX splitter will eventually deteriorate the digital signal.

The fixture's channel range must not overlap any other device's channel range on the link. When two devices on the same DMX link have overlapping channel ranges, one or both devices will be disabled or behave erratically.

**Note** The single exception to the non-overlapping rule is if the fixtures are the same type (for example two Technobeams set to iris protocol) and share the *entire* channel range.

## Determining the Unique DMX Start Channel

The DMX start channel is the first channel available to a fixture in its channel range. To determine each fixture's DMX start channel in a link, you must know the number of DMX channels used by each fixture (see "Fixture Types" on page 2-13).

Knowing that the first fixture on the link will use DMX start channel 1, you can determine the DMX start channel for each successive fixture by adding the number of DMX channels used by the fixture to the fixture's DMX start channel. For example, in Table 2-2, 18 (channels used by the Technobeam set to iris protocol) + 1 (DMX start channel for the first fixture) = 19 (DMX start channel for the next fixture on the link).

*Table 2-2. Example: Determining the DMX Start Channel*

Fixture location on the link*	Fixture name	Number of DMX channels used per fixture	DMX start channel	Channel range used
First	Technobeam (iris protocol)	18 channels	C001	1-18
Second	Technobeam (full protocol)	18 channels	C019	19-36
Third	Technobeam (reduced protocol)	14 channels	C037	37-50
Fourth	Other Device (using 12 channels)	12 channels	C051	51-62
Fifth	Technobeam (iris protocol)	18 channels	C063	63-80

**\*Note** The fixture location on the link does not have to comply with this example. The fixtures can be addressed in any order on the link.

To assign a unique DMX start channel for the fixture:

1. Press and hold the <Menu> button until “ADDR” appears on the LED display.
2. Press the <Enter> button to enter the “ADDR” menu.

3. Using the <Up> and <Down> arrow buttons, scroll to the desired DMX start channel and press the <Enter> button to select the desired DMX start channel.

**Note** You must assign a unique fixture address to *each* Studio Spot 250 or Studio Color 250 fixture that you wish to respond independently to controller commands.

## Determining the Unique Fixture Number

The fixture number is a number you assign that represents each unique fixture’s channel range in the DMX 512 link. If you are using one DMX link to control fixtures which all use the same number of DMX channels (as recommended), you can assign fixture numbers in ascending order (see Table 2-3).

Table 2-3. Example: Determining the Unique Fixture Number

Fixture location on the link	Fixture name	Number of DMX channels used per fixture	Fixture number	Channel range used
First	Technobeam (iris protocol)	18 channels	F 01	1-18
Second	Technobeam (iris protocol)	18 channels	F 02	19-36
Third	Technobeam (full protocol)	18 channels	F 03	37-54
Fourth	Other device (using 18 channels)	18 channels	F 04	55-72

To assign a unique fixture number to your fixture:

1. Press and hold the <Menu> button until “ADDR” appears on the LED display.
2. Press the <Enter> button to enter the “ADDR” menu.

3. Using the <Up> and <Down> arrow buttons, scroll to the desired fixture number and press the <Enter> button.

**Note** You must assign a unique fixture address to *each* Technobeam fixture that you wish to respond independently to controller commands.

## Wasted DMX Channels

If you mix different types of devices (which use different numbers of channel ranges) on the same DMX link and assign fixture numbers

(instead of DMX start channels) to these devices, you would waste DMX channels.

For example, in Table 2-4, if you assigned fixture number 2 (F 02) to the Technobeam set to reduced protocol, it would assume that all other fixtures on the link are also using 14 DMX channels, so it will erroneously try to receive channel 15 as the first channel in its channel range. This would create channel overlapping because fixture number 1 (Technobeam iris protocol) is already using channel 15 in its 18-channel range.

In this example, to prevent overlapping channels, you must assign fixture number 3 (F 03) to the Technobeam (reduced protocol), even though it is physically the second fixture on the DMX link. While this would prevent overlapping channels, it would result in wasted channels that could not be used (see Table 2-4).

*Table 2-4. Example of Wasted DMX Channels*

<b>Fixture location on the link</b>	<b>Fixture name</b>	<b>Number of DMX channels used per fixture</b>	<b>Fixture number: DMX channel range used (to prevent overlapping)</b>	<b>Resulting channels wasted</b>
First	Technobeam (iris protocol)	18 channels	<b>F 01</b> : 01-18	
Second	Technobeam (reduced protocol)	14 channels	<b>F 03</b> : 29-42	11 channels wasted (19-29)
Third	Technobeam (iris protocol)	18 channels	<b>F 04</b> : 55-72	13 channels wasted (43-54)
Fourth	Technobeam (reduced protocol)	14 channels	<b>F 07</b> : 85-98	12 channels wasted (73-84)

Therefore, if you choose to assign fixture numbers to different types of devices (and/or protocols) on the same DMX link, refer to “Fixture Number to DMX Start Channel” on page A-16, which shows the channel ranges reserved for each Technobeam fixture type. This table will help you determine the next available DMX start channel/fixture number for successive Technobeam fixtures on the link.

# Upgrading Software

There are three ways you can upgrade the *software* (fixture-specific operational code) to Technobeam fixtures attached to a DMX link:

- **Attaching a High End Systems upload dongle.** You will need an upload dongle, 386-based (or faster) computer, MS DOS® version 3.3 (or later), and one MB of free disk space. To obtain an upload dongle (with installation and operation instructions), contact your High End Systems dealer/distributor (see “Contacting High End Systems” on page Intro-4).
- **Crossloading software between fixtures.** You will need one Technobeam fixture with updated software and you can then load the software across the DMX link to all other Technobeam fixtures on the same link. For more information on crossloading software, see the next section.

## Crossloading Software

The procedure that follows assumes you already have some familiarity with the menu system; if not, see Chapter 3 and the menu map located inside the back cover of this manual.

1. Remove or bypass all controllers, non-High End Systems fixtures, optoisolators or serial data distributors on the link. These devices will prevent crossloading.
2. If there are any Dataflash AF1000 xenon strobe fixtures, Emulator laser simulators or Intellabeam automated luminaires on the same link, make sure they are all *after* all of the Technobeam fixtures. If not, you must bypass all AF1000s, Emulators or Intellabeams until the upload is complete.
3. Determine which Technobeam fixture has the newest software. Skip to Step 4 if you already know the software version on all your fixtures.

INFO

VER

- a. Navigate to the **INFO** menu.
- b. Press <Enter> then use the <Up> or <Down> arrow keys to navigate to the **VER** option.
- c. Press <Enter>; the fixture’s software version will be displayed similar to Figure 2-12:

Addr

MODE

XLd



Figure 2-12. This fixture has software version 3.

4. Once you are sure which fixture has the newest software (the *crossloading* fixture), press and keep pressing the <Menu> key on that

- fixture until the **ADDR** option is displayed.
5. Use the <Up> or <Down> arrow keys to navigate to the **MODE** menu.
  6. Press <Enter> and use the <Up> or <Down> arrow keys to navigate to the **XLD** option.
  7. Press <Enter> to start the crossload. The Transmit LED on the crossloading fixture will remain ON (or flicker) during the crossload. The Transmit and Receive LEDs on other Technobeam fixtures on the link will flicker while the crossload is in progress.
  8. When the crossload has finished successfully, the following will happen:
    - **DONE** will appear briefly in the LED display of the crossloading fixture, followed by MENU which will alternate with the fixture's fixture number or DMX start channel.
    - All of the other Technobeam fixtures will home themselves.
  9. Otherwise, if an error message is displayed, see the section titled "Menu Error Messages" on page 2-25.

## Troubleshooting

---

This section lists typical symptoms and solutions for problems you might encounter when using your fixture. If you need additional help, contact your dealer/distributor or High End Systems Customer Service in one of the ways shown in the section titled "Contacting High End Systems" on page Intro-4.



**WARNING** This information is intended to assist qualified service personnel because this fixture is to be serviced by qualified service personnel *only*.

### **Fixture does not work: no LEDs, fan, lamp, or other functionality**

Possible causes and solutions:

1. *Cause:* No input power.  
*Solutions:* Do all of the following:
  - a. Verify that the fixture is plugged into a working power supply.
  - b. Verify the integrity of the power cord and the wiring of the power cord cap as shown in the section titled "Installing the Power Cord Cap" on page 1-7.
2. *Cause:* One or more fuses have failed.  
*Solution:* Follow the directions in the section titled "Replacing Fuses" on page 6-2 to replace the necessary fuses.

### **Lamp does not strike**

Possible causes and solutions:

1. *Cause:* Improper voltage setting or power cord cap wiring.  
*Solutions:* Do both of the following:
  - a. Make sure the fixture is set for the same voltage as the power supply. See “Setting the Fixture Voltage” on page 1-10.
  - b. Make sure the power cord cap is wired correctly. See “Installing the Power Cord Cap” on page 1-7.
2. *Cause:* One or more fuses have failed.  
*Solution:* Follow the instructions in the section titled “Replacing Fuses” on page 6-2 to inspect the fuses and replace them if necessary.
3. *Cause:* Bad lamp.  
*Solution:* Replace with a new or known good lamp.

### Lamp shuts off

Possible causes and solutions:

1. *Cause:* Over-temperature. An over-temperature condition can be confirmed by the message **OVER TEMP** on the fixture’s LED display.  
*Solution:* See the section titled “Menu Error Messages” on page 2-25.
2. *Cause:* Fan has failed.  
*Solution:* Home the fixture, either by unplugging the fixture and plugging it back in, or by selecting **HOME** from the Test menu. Put your hand over the exhaust vent shown in Figure 2-13. You should feel a slight breeze from the fan. If not, the fan has failed. Contact High End Systems Customer Service as shown in “Contacting High End Systems” on page Intro-4.

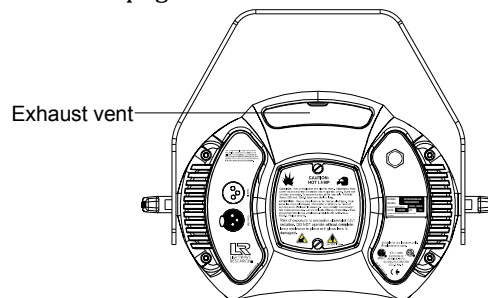

Figure 2-13. Location of the fixture’s exhaust vent.

3. *Cause:* Lamp socket is loose, causing arcing.  
*Solution:* Replace the lamp socket assembly. Call your High End Systems dealer/distributor for more information.

4. *Cause:* Aging lamp.

*Solution:* Replace with a new or known good lamp.



## **Fixture is not responding to control commands—“Receive” LED does not blink**

Possible causes and solutions:

1. *Cause:* Faulty XLR cable.  
*Solutions:* Do one or both of the following:
  - a. Replace XLR cables going to the fixture’s Data In and Data Out connectors with known good cables.
  - b. Verify cable integrity using cable test equipment.
2. *Cause:* There is no controller attached to the link, or the controller is not generating any output.  
*Solution:* Verify that a controller is attached to the link. Verify that the controller is generating output by sending commands to a known working device.  
Also see the section titled “Troubleshooting DMX Data” on page 2-24.
3. *Cause:* One or more fuses have failed.  
*Solution:* Follow the instructions in the section titled “Replacing Fuses” on page 6-2 to inspect the fuses and replace them if necessary.

## **Dim flags close, fixture does not respond to control commands, lamp shuts off, fan turns off**

Possible causes and solutions:

1. *Cause:* Faulty XLR cable.  
*Solutions:* Do one or both of the following:
  - a. Replace XLR cables going to the fixture’s Data In and Data Out connectors with known good cables.
  - b. Verify cable integrity using cable test equipment.
  - c. See the section titled “Troubleshooting DMX Data” on page 2-24.
2. *Cause:* One or more fuses have failed.  
*Solution:* Follow the instructions in the section titled “Replacing Fuses” on page 6-2 to replace the necessary fuses.

## **Color wheel or litho wheel is not centered in the beam or is in the wrong position**

*Cause:* Non-High End Systems dichroic or litho does not meet specifications. A litho that is slightly under the recommended thickness, for example, can turn in the wheel as the wheel rotates, causing the litho to become uncentered.

*Solution:* Make sure all dichroics and lithos meet the specifications listed in the section titled “Specifications” on page 6-4.

### **Lithos or dichroic filters are cracking**

Possible causes and solutions:

1. *Cause:* Improper installation.

*Solution:*

- a. **General:** Make sure you are using dichroics and lithos that meet the specifications shown in the section titled “Specifications” on page 6-4.
- b. **Lithos:** Lithos must be oriented with the coated side facing *away from* the lamp and the glass (uncoated) side facing *toward* the lamp. In the case of textured lithos, face the textured side away from the lamp and the flat side toward the lamp.
- c. **Color wheel dichroic filters:** Dichroic filters should be oriented with the coated side facing *toward* the lamp and the glass (uncoated) side facing *away from* the lamp. Figure 6-5 on page 6-6 shows how to tell which side is which.

2. *Cause:* Faulty hot mirror allowing overheating inside the fixture.

*Solution:* Visually inspect the hot mirror for cracks or deep scratches as shown in the section titled “Cleaning the Lenses and Mirrors” on page 6-16.

3. *Cause:* Fan has failed.

*Solution:* Home the fixture, either by unplugging the fixture and plugging it back in, or by selecting **HOME** from the Test menu. Put your hands over the air exhaust shown in Figure 2-13 on page 2-21. You should feel air movement. If not, the fan has failed. Contact High End Systems Customer Service as shown in “Contacting High End Systems” on page Intro-4.

### **Other components cracked or heat damaged**

Possible causes and solutions:

1. *Cause:* Faulty hot mirror allowing overheating inside the fixture.

*Solution:* Visually inspect the hot mirror for cracks or deep scratches (see “Cleaning the Lenses and Mirrors” on page 6-16).

2. *Cause:* Fan has failed.

*Solution:* Home the fixture, either by unplugging the fixture and plugging it back in, or by selecting **HOME** from the Test menu. Put your hands over the air exhaust shown in Figure 2-13 on page 2-21. You should feel a slight breeze from the fan. If not, the fan has failed. Contact High End Systems Customer Service as shown in “Contacting High End Systems” on page Intro-4.

## **Fixture will not accept software upload or crossload**

Possible causes and solutions:

1. *Cause:* No return communication (indicated by Transmit LEDs OFF for all fixtures on the link when you are trying to perform the crossload or upload).

*Solution:* Make sure you bypass any AF1000 fixtures, Intellabeam fixtures, Emulator fixtures, non-High End Systems fixtures, optoisolators or serial data distributors. These devices stop the communication required for software crossloads or uploads. See the section titled “Setting up the Link” on page 2-6 for more information.

## **Low light output, fuzzy images**

Possible causes and solutions:

1. *Cause:* Incorrect lens installation.

*Solution:* Make sure you have installed the lenses in the correct orientation, as shown in the section titled “Setting the Beam Angle” on page 1-12.

2. *Cause:* Aging lamp.

*Solution:* Replace the lamp with a new or known good lamp.

3. *Cause:* Dirty optical path.

*Solution:* Clean all lenses, filters, lithos and the anti-reflective glass as shown in the section titled “Cleaning the Internal Components” on page 6-15.

## **Troubleshooting DMX Data**

This section explains how to use the DMX diagnostics built into Technobeam to isolate the origin of data problems either in the fixture or in the DMX 512 link. The instructions in this section should be followed *only* by people with a good understanding of DMX 512 protocol and the fixture’s menu system.

If you are having trouble with a fixture(s) on your DMX 512 link, you should first review the following:

1. Are DMX 512 control commands being “misinterpreted” by the fixture? If so, make sure the controller is configured for the correct fixture type. For example, if you have a Technobeam set for full, 18-channel protocol, but the controller is sending Technoray channel values, none of the values you send from the controller will have the expected effect. Continuing the same example, sending a value on channel 8 (which is effect wheel spin speed for Technoray) will result in selecting a rotating litho wheel position on Technobeam.

2. Is more than one device affected? If so, and the devices are addressed sequentially on the link, check to make sure addressing was done properly on all affected devices. In particular, if you are using fixture numbering, review the DMX channel boundaries for all affected fixtures. Table A-5 on page A-16 shows fixture number to DMX channel boundaries for Technobeam.
3. Make sure the last device on the link is terminated.
4. Are the gears and motors moving at all? If not, check for a loose cable connection or a cable break somewhere on the link. If possible, verify cable integrity or replace questionable cable with known good cable.
5. Make sure the controller is generating output. Consult the documentation provided with the controller for more information.
6. Verify the DMX data for other fixtures on the link (see “Viewing DMX Status and Construct Values (FIXT)” on page 3-24 or “Viewing DMX Data for Another Device (DATA)” on page 3-26).

## **Menu Error Messages**

This section lists the possible error messages that can appear on the fixture’s LED display, as well as suggested actions. If the suggested action does not solve the problem or if you have additional questions, contact High End Systems Customer Service in one of the ways shown in the section titled “Contacting High End Systems” on page Intro-4.

### **Addr Lost**

The fixture’s software was unable to retrieve the fixture number or DMX start channel from non-volatile storage. Try unplugging the fixture, waiting a short time, then plugging it back in. If this error message reoccurs, contact High End Systems Customer Service in one of the ways shown in the section titled “Contacting High End Systems” on page Intro-4.

### **Boot Diff**

(Boot difference error.) This message may occur after a software upload or crossload if new boot software has been included in the upload. Selecting **BOOT** from the Test menu will copy the new boot to the boot software storage area, and correct the cause of this error message.

### **EMEM Ack**

This error may occur during data storage when an attempted write has taken too long. Attempt the operation again. If this message reoccurs, contact High End Systems Customer Service in one of the ways shown in the section titled “Contacting High End Systems” on page Intro-4.

## EMEM [message]

(Memory error.) This error indicates the fixture was unable to retrieve one of the following from non-volatile storage:

- **CHNL**—the fixture’s DMX start channel.
- **DPLY**—LED display status (on, off, dim).
- **FHRS**—number of fixture operating hours.
- **LENS**—lens set selection (NORM for factory-installed or optional narrow angle set, WIDE for optional wide angle lens set).
- **LHRS**—number of lamp operating hours.
- **L/ST**—lamp strikes.
- **MODE**—preset playback status (ON/OFF/SCN).
- **PERS**—the fixture’s protocol (e.g., Technobeam full protocol).
- **PINV**—pan invert status.
- **TINV**—tilt invert status.
- **S/DN**—shutdown time.
- **SWAP**—pan/tilt swap status.
- **TIMB**—time base (seconds, minutes, hours) for preset playback.

The most likely cause is that an electrical event occurred and either interrupted data storage or caused the non-volatile memory to be corrupted. Try restoring the lost items manually. If the problem persists, contact High End Systems Customer Service in one of the ways shown in the section titled “Contacting High End Systems” on page Intro-4.

## Erse Flsh

Occurs during a crossload when the time required to erase a fixture’s memory is excessive. Remove the fixture from the link and contact High End Systems Customer Service. You might need to restart the crossload as well.

## ID Lost

The system software was unable to read the fixture’s ID number (fixture number or DMX start channel) from its non-volatile storage area. Try unplugging the fixture, waiting a short time, then plugging it back in. If this error message reoccurs, contact High End Systems Customer Service in one of the ways shown in the section titled “Contacting High End Systems” on page Intro-4.

## Lamp

The word LAMP can appear on the display in two situations: one is an error; the other is normal.

- **Normal:** LAMP will be displayed when the fixture attempts to strike the lamp during fixture reset and homing. This is normal.

- **Not normal:** If the lamp is running, and for some reason—probably an electrical event—the fixture’s operating code loses track of the lamp status, the lamp will turn off and the word “LAMP” will appear in the LED display. Allow the fixture 5 to 10 minutes to cool before trying to turn the lamp on again.

## Link Busy

Occurs when the crossloading fixture detects that some other source is driving data on the link. For crossloads to work properly, you must remove or bypass all of the following if they are on the same link:

- Serial data distributors
- Optoisolators
- Non-High End Systems fixtures
- Controllers
- AF1000, Emulator or Intellabeam fixtures: Placing all AF1000, Emulator or Intellabeam fixtures *after* all Technobeam fixtures is a good way to do this.

After removing the offending device(s) from the data link, attempt the crossload again.

## Link Empty

Occurs when the crossloading fixture fails to find any other Technobeam fixtures. If there are indeed other fixtures on the link, a communication failure has occurred.

Possible causes include:

1. A bad data cable between the crossloading fixture and the first fixture on the data link. Verify cable integrity with cable test equipment or replace with known good cabling.
2. See “Link Busy” above.
3. One or more fixtures are powered off. Connect all fixtures on the link to appropriately-rated power outlets and try again.
4. If none of the above solves the problem, the most likely cause is that an electronics failure has occurred in the data section of one of the fixtures on the data link. Try powering off one fixture at a time and attempting the crossload. If you can isolate the crossload problem to one fixture in particular, remove that fixture from the link and contact High End Systems Customer Service in one of the ways shown in the section titled “Contacting High End Systems” on page Intro-4.

## Over Temp

The internal fixture temperature has exceeded the maximum allowable temperature. The lamp and the motors will shut down.

1. The primary external cause is high ambient air temperature. The fixture’s maximum ambient temperature rating is shown in the section

- titled “Environmental Specifications” on page 1-5. Unplug the fixture and wait 5 to 10 minutes for it to cool before plugging it back in.
2. If allowing the fixture to cool does not solve the problem, check to make sure the fan is working. Home the fixture, either by selecting **HOME** from the Test menu, or by unplugging the fixture and plugging it back in. Place your hand over the air exhaust shown in Figure 2-13 on page 2-21. You should feel air movement. If not, the fan has failed. Contact High End Systems Customer Service in one of the ways shown in the section titled “Contacting High End Systems” on page Intro-4.
  3. If the fan is working, unplug the fixture and verify the voltage setting matches the power supply as shown in the section titled “Setting the Fixture Voltage” on page 1-10. If the voltage setting is correct, contact High End Systems Customer Service in one of the ways shown in the section titled “Contacting High End Systems” on page Intro-4.

## **PRST Lost**

(Preset Lost.) Scenes (presets) stored in the fixture’s onboard sixteen-scene memory were lost.

The causes and solution for this error are the same as for “EMEM [message]”.

## **PGRM Time**

Occurs during a crossload when a receiving fixture has exceeded the maximum allowable programming time. The crossloading fixture will make a number of attempts to send new program data to each of the receiving fixtures. If the receiving fixtures fails to respond properly after a number of programming attempts have been made, the crossloading fixture will drop the offending fixture from the upload list, and display this error message.

Remove one fixture at a time from the link and attempt the crossload again until you can isolate the crossload problem to a particular fixture. Contact High End Systems Customer Service in one of the ways shown in the section titled “Contacting High End Systems” on page Intro-4.

## **Shut Down**

The fixture has received a Shutdown command from the controller and has shut down; i.e., the lamp and motors have been turned off. Homing the fixture will bring it out of shutdown.





# Chapter 3

## Using the Menus

Menu System Overview .....	3-2
Navigation Buttons .....	3-2
Accessing the Menu System .....	3-2
Menu Map .....	3-3
Menu Options .....	3-10
Address Menu (ADDR) .....	3-10
Set Menu (SET) .....	3-11
Setting Factory Defaults (FACT) .....	3-11
Swapping Pan and Tilt (SWAP) .....	3-12
Inverting Tilt (T/IN) .....	3-12
Inverting Pan (P/IN) .....	3-12
Changing the Display Output (DSPL) .....	3-13
Inverting LED Characters (D/IN) .....	3-13
Changing the Control Method (CHNL) .....	3-13
Setting the Lamp Warning Message (LMPL) .....	3-14
Changing the Lens Setting (LENS) .....	3-14
Mode Menu (MODE) .....	3-15
Setting the Fixture Type and Protocol (TYPE) .....	3-15
Setting the User Type (USER) .....	3-16
Copying User Presets (PRST) .....	3-17
Copying User Settings (SETT) .....	3-18
Copying User Presets and Settings (ALL) .....	3-18
Crossloading Fixture Software (XLD) .....	3-19
Test Menu (TEST) .....	3-20
Homing the Fixture (HOME) .....	3-20
Turning the Lamp On or Off (LAMP) .....	3-20
Copying the Boot Code (BOOT) .....	3-21
Performing Self Tests (SELF) .....	3-21
Placing the Fixture in Setup Mode (S/UP) .....	3-22
Testing the LED Display (DISP) .....	3-22
Information Menu (INFO) .....	3-22
Viewing the Logic Board Temperature (TEMP) .....	3-23
Viewing the Current Lamp Hours (L/HR) .....	3-23
Viewing the Current Fixture Hours (F/HR) .....	3-23
Viewing the Number of Current Lamp Strikes (L/ST) .....	3-24
Viewing the Current Software Version (VER) .....	3-24
Viewing DMX Status and Construct Values (FIXT) .....	3-24
Viewing DMX Data for Another Device (DATA) .....	3-26
Viewing Sensor Information (SENS) .....	3-26
Resetting Fixture Hours (F/RS) .....	3-27
Resetting Lamp Hours (L/RS) .....	3-27
Preset Menu (PRST) .....	3-28
Setting Preset Playback (PLAY) .....	3-28
Editing or Creating an On-Board Memory Scene (EDIT) .....	3-29
Copying an On-Board Memory Scene (COPY) .....	3-29
Capturing a Preset Scene (CAPT) .....	3-29
Enabling the Preset Default (DFLT) .....	3-30

# Menu System Overview

The Technobeam menu system allows you to:

- Configure your fixture for operation (discussed in Chapter 2)
- Access fixture options such as homing the fixture, crossloading software, and performing self tests (discussed in this chapter)
- Use preset programming to create, store, and play back scenes from the fixture's onboard memory (see Chapter 4)

## Navigation Buttons

The navigation buttons on the fixture's display panel allow you to navigate through the onboard menu system. As you navigate the menu system, the alphanumeric display will show the menu items you select from the menu map.

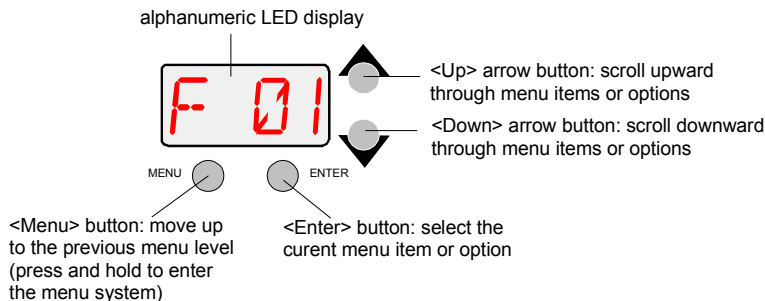

Figure 3-1. Technobeam navigation buttons.

The alphanumeric display will flash when a new option is *selected* (by pressing the <Up> and <Down> arrow buttons), and will stop flashing when a new option is *entered* (by pressing the <Enter> button).

**Note** If you do not press the <Enter> button, the new option you selected will not be stored.

Pressing the <Menu> button returns you to the previous option or menu *without changing* the value of an option.

## Accessing the Menu System

To access the menu system, press and hold the <Menu> key until "ADDR" appears on the LED display. The menu system is protected against inadvertent menu changes by requiring the <Menu> button to be held for a few seconds before allowing entry to the menus.

To exit the menu system, you must keep pressing the <Menu> button to back out of each menu level until "MENU" appears on the LED display. "MENU" will be replaced, after a few seconds, with the default alternating display of the fixture's software version and the fixture number/DMX start channel.

# Menu Map

A complete menu map and explanations of the Technobeam menu options are listed in this section. See individual subsections in this addendum for descriptions of each menu item.

Chapter 4 has more information about using the menus to program the fixture's sixteen onboard scenes (presets).

**Note** If your Technobeam-i does not have an iris and/or Laser Aiming Device™ (LAD®), the iris and LAD-related menu items listed below will have no functionality.

Although Technopro and Technoray fixtures have been discontinued, their menu options still exist in the protocol, and are listed below.

Table 3-1. Technobeam Menu Map

Menu Level 1	Menu Level 2	Menu Level 3	Menu Level 4	Menu Level 5	Description
ADDR	Fxx/Cxxx				change the existing fixture number/DMX start channel
SET	FACT	ON			set factory defaults on
		OFF			set factory defaults off <i>Note: Selecting this option has no affect on individual preset values.</i>
	SWAP	ON			set pan/tilt swap on
		OFF			set pan/tilt swap off
	T/IN	ON			set tilt invert on
		OFF			set tilt invert off
	P/IN	ON			set pan invert on
		OFF			set pan invert off
	DSPL	ON			set LED display on
		OFF			set LED display off
		DIM			dim LED display
	D/IN	ON			invert LED display orientation
		OFF			set normal LED display orientation
	CHNL	DMX			set control method to DMX start channel
		ADDR			set control method to fixture number
	LMPL	ON			enable lamp hour warning message
OFF				disable lamp hour warning message	
LENS	NORM			factory lens or narrow angle lens setting	
				wide angle lens setting	
	NARW			standard or narrow angle lens setting that increases the distance the lens tube can move to allow for a greater throw distance <i>Note: This option is not for use with wide angle lenses.</i>	

Table 3-1. Technobeam Menu Map

Menu Level 1	Menu Level 2	Menu Level 3	Menu Level 4	Menu Level 5	Description		
MODE	TYPE	TB F			Technobeam full protocol (uses 18 channels)		
		TB R			Technobeam reduced protocol (uses 14 channels)		
		TR F			Technoray full protocol (uses 14 channels)		
		TR R			Technoray reduced protocol (uses 12 channels)		
		TPRO			Technopro protocol (uses 12 channels)		
		TB I			Technobeam-i (uses 18 channels)		
		TLCD			Technopro used with an LCD controller (uses 18 channels)		
	XLD				crossload fixture software to all other Technobeam, Technoray, and Technopro fixtures on the link		
	USER	A				user A settings	
		B				user B settings	
		COPY	PRST	A -> B			copy user A presets to user B
				B -> A			copy user B presets to user A
			SETT	A -> B			copy user A settings to user B
				B -> A			copy user B settings to user A
		ALL	A -> B			copy user A presets and settings to user B	
B -> A				copy user B presets and settings to user A			
TEST	HOME				home the fixture		
	LAMP	LOFF			extinguish the lamp		
		L ON				strike the lamp	
	BOOT				copy the boot sector		
	SELF	ALL				self test all constructs	
		PAN				self test mirror pan movement	
		TILT				self test mirror tilt movement	
		COL				self test color wheel movement	
		LTO				self test litho wheel movement	
		FX				self test effects wheel movement	
		FCUS				self test lens tube movement	
		IRIS				self test iris movement	
		SHUT				self test shutter strobe movement	
	DIM				self test shutter dim flag movement		
	S/UP	SET NOW				place the fixture in setup mode for mechanical homing <i>Note: When the display shows "SET NOW," mechanically home the fixture, then press any key to exit this menu option.</i>	
DISP					self test the alphanumeric LED display		
CODE					<i>Factory use only</i>		
INFO	TEMP				view the fixture's current internal temperature		
	L/HR				view the current number of lamp hours		
	F/HR				view the current number of fixture hours		
	L/ST				view the current number of lamp strikes		
	VER				view the fixture's software version		

Table 3-1. Technobeam Menu Map

Menu Level 1	Menu Level 2	Menu Level 3	Menu Level 4	Menu Level 5	Description
INFO	DMX	FIXT	BRKS		view the number of framing errors with zero data (DMX breaks)
			FE		view the number of framing errors with non-zero data
			OV		view the number of DMX overruns
			STRT		view the DMX start code value
			PANH		view the DMX high resolution pan value
			PANL		view the DMX low resolution pan value
			TLTH		view the DMX high resolution tilt value
			TLTL		view the DMX low resolution tilt value
			COLC		view the DMX color wheel control value
			COL		view the DMX fixed color wheel position value
	DMX	FIXT	LTOC		view the DMX litho wheel control value
			LTO		view the DMX litho wheel position value
			LTR		view the DMX litho rotation value
			FCUS		view the DMX lens tube position value
			FX		view the DMX effects wheel position value
			FXR		view the DMX effects wheel rotation value
			IRIS		view the DMX iris position value
			SHUT		view the DMX shutter strobe value
			DIM		view the DMX shutter dim flag value
			MSPD		view the DMX MSpeed time value
			LAD		view the DMX Laser Aiming Device (LAD) value
			CNTL		view the DMX control channel value
	DATA	C001 - C512			view the DMX data for the selected DMX channel <i>Note: You can only view DMX channels lower than the last channel in the viewing fixture's channel range.</i>
	SENS	LTR	ON		the litho rotate (within the wheel) sensor is not obstructed
			OFF		the litho rotate (within the wheel) sensor is obstructed
		LTO	ON		the litho wheel sensor is not obstructed
			OFF		the litho wheel sensor is obstructed
		COLR	ON		the color wheel sensor is not obstructed
			OFF		the color wheel sensor is obstructed
		FX	ON		the effects wheel sensor is not obstructed
			OFF		the effects wheel sensor is obstructed
	F/RS			reset fixture hours to zero ( <i>press and hold the &lt;Enter&gt; button until the display shows "0000"</i> )	
L/RS			reset lamp hours to zero ( <i>press and hold the &lt;Enter&gt; button until the display shows "0000"</i> )		
UNUM			<i>Customer Service use only</i>		
PRST	PLAY	OFF		set preset playback off	
		ON		set preset playback on	
		SCN		display which scene is currently playing	

Table 3-1. Technobeam Menu Map

Menu Level 1	Menu Level 2	Menu Level 3	Menu Level 4	Menu Level 5	Description
PRST	EDIT	SN01 - SN16	SHUT	CLSD	shutter closed
				P 01 - P 60	periodic shutter strobe at specified intervals, slow (P 01) to fast (P 60)
				N 01 - N 60	random shutter strobe at random intervals, slow (N 01) to fast (N 60)
				RS01 - RS60	shutter ramp open, slow (RS01) to fast (RS60), snap shut
				SR01 - SR60	shutter snap open, ramp shut slow (SR01) to fast (SR60)
				OPEN	shutter open
			DIM	D000 - D255	select a dim value from dark (D000) to bright (D255)
			PAN		mirror pan from -89.9 to +89.9
			TILT		mirror tilt from -44.9 to +44.9
			COLC	IDX	color wheel indexed position (wheel snaps to center of color), full speed
				FSP	color wheel forward spin, full speed
				RSP	color wheel reverse spin, full speed
				CON	color wheel continuously-variable position, full speed
				SSC	color wheel slow scanning, full speed
				FSC	color wheel fast scanning, full speed
				RND	color wheel random color positions, full speed
				BLK	color wheel blink selection, full speed
				MIDX	color wheel indexed position, MSpeed
				MFSP	color wheel forward spin, MSpeed
				MRSP	color wheel reverse spin, MSpeed
				MCON	color wheel continuously-variable position, MSpeed
				MSSC	color wheel slow scanning, MSpeed
				MFSC	color wheel fast scanning, MSpeed
				MRND	color wheel random color positions, MSpeed
				MBLK	blink selection (wheel snaps to center of color and the shutter closes between positions), MSpeed
				COL	C 1 - C 13
			HC 1 - HC13		select a half color position (only available if you selected a COLC construct value of IDX or MIDX)
			F000 - F255		select a forward color wheel spin speed from none (F000) to fast (F255) (only available if you selected a COLC construct value of FSP or MFSP)

Table 3-1. Technobeam Menu Map

Menu Level 1	Menu Level 2	Menu Level 3	Menu Level 4	Menu Level 5	Description
PRST	EDIT	SN01-SN16	COL	R000 - R255	select a reverse color wheel spin speed from none (R000) to fast (R255) (only available if you selected a COLC construct value of RSP or MRSP)
				D000 - D358	select a color wheel position in degrees from 0° (D000) to 358° (D358) (only available if you selected a COLC construct value of CON or MCON)
				SC 1 - SC26	slow scan of selected full color base position (SC 1 - SC13) or half color base position (SC14 - SC26) (only available if you selected a COLC construct value of SSC or MSSC)
				FC 1 - FC26	fast scan of selected full color base position (FC 1 - FC 13) or half color base position (FC14 - FC26) (only available if you selected a COLC construct value of FC or MFC)
				N000 - N255	select a pause time between random color wheel position changes, short (N000) to long (N255) (only available if you selected a COLC construct value of RND or MRND)
				B 1 - B 13	shutter blink on selected full color position (only available if you selected a COLC construct value of BLK or MBLK)
				HB 1 - HB13	shutter blink on selected half color position (only available if you selected a COLC construct value of BLK or MBLK)
			LTOC	IDX	litho wheel indexed position (wheel snaps to center of litho), full speed
				FSP	litho forward spin, full speed
				RSP	litho reverse spin, full speed
				SC	litho wheel scanning, full speed
				BLK	litho wheel blink selection, full speed
				RND	litho wheel random color positions, full speed
				WSP	litho wheel spin, full speed
				MIDX	litho wheel indexed position, MSpeed
				MFSP	litho forward spin, MSpeed
				MRSP	litho reverse spin, MSpeed
				M SC	litho wheel scanning, MSpeed
				MBLK	litho wheel blink selection (wheel snaps to center of litho and the shutter closes between positions), MSpeed
				MRND	litho wheel random color positions, MSpeed
			MWSP	litho wheel spin, MSpeed	
			LTO	L 1 - L 8	select a litho wheel position (only available if you selected a LTOC construct value of IDX or MIDX)
				LF 1 - LF 8	select a forward spinning litho position (only available if you selected a LTOC construct value of FSP or MFSP)

Table 3-1. Technobeam Menu Map

Menu Level 1	Menu Level 2	Menu Level 3	Menu Level 4	Menu Level 5	Description	
PRST	EDIT	SN01-SN16	LTO	LR 1 - LR 8	select a reverse spinning litho position (only available if you selected a LTOC construct value of RSP or MRSP)	
				SC 1 - SC 8	scan selected litho base position (only available if you selected a LTOC construct value of SC)	
				B 1 - B 8	select a litho wheel position (only available if you selected a LTOC construct of BLK or MBLK)	
				RAND	(because "Random" was selected for litho control, no litho position can be assigned)	
				WSPN	(because "Wheel Spin" was selected for litho control, no litho position can be assigned)	
			LTR	D000 - D358	select a litho angle from 0° (D000) to 358° (D358) (only available if you selected a LTOC construct value of IDX, BLK, MIDX, or MBLK)	
				F000 - F255	select a litho's forward spin speed from none (F000) to fast (F255) (only available if you selected a LTOC construct value of FSP or MFSP)	
				R000 - R255	select a litho's reverse spin speed from none (R000) to fast (R255) (only available if you selected a LTOC construct value of RSP or MRSP)	
				S000 - S255	select a litho scan speed from slow (S000) to fast (S255) (only available if you selected a LTOC construct value of SC or MSC)	
				N000 - N255	select a pause time between random litho selections from long (N000) to short (N255) (only available if you selected a LTOC construct value of RND or MRND)	
				WF01 - WF12	select a litho wheel forward spin speed from slow (WF01) to fast (WF12) (only available if you selected a LTOC construct value of WSP or MWSP)	
				WR12 - WR01	select a litho wheel reverse spin speed from fast (WR12) to slow (WR01) (only available if you selected a LTOC construct value of WSP or MWSP)	
				FCUS	000 - 255	select the lens tube position
				FX	FX 1 - FX 5	select an effects wheel position, full speed
					MFX1 - MFX5	select an effects wheel position, MSpeed
				FXR	F001 - F121	select an individual effect's forward spin speed from fast (F001) to slow (F121)
					R001 - R121	select an individual effect's reverse spin speed from slow (R001) to fast (R121)



Table 3-1. Technobeam Menu Map

Menu Level 1	Menu Level 2	Menu Level 3	Menu Level 4	Menu Level 5	Description
PRST	EDIT	SN01-SN16	IRIS	OPEN	fully open the iris
				P 01 - P 16	select a speed to strobe the beam diameter, from slow (P 01) to fast (P 16)
			IRIS	N 01 - N 16	select a random frequency to strobe the beam diameter, from less often (N 01) to more often (N 16)
				RS01 - RS16	select the speed to ramp open, slow (RS01) to fast (RS16), then snap shut
				SR01 - SR16	select the speed to snap open, then ramp shut slow (SR01) to fast (SR16)
				RR01 - RR16	select the speed to ramp open, then ramp shut slow (RR01) to fast (FF16)
				NR01 - NR16	select the random frequency to ramp open, from less often (NS01) to more often (NS16), then snap shut
				NS01 - NS16	select the random frequency to snap open, then ramp shut from less often (NR01) to more often (NS16)
				CLSD	close the iris
				I001 - I127	select a beam diameter, from small (I001) to large (I127)
			MSPD	0.15 - 252.7	select an MSpeed value in decimal seconds from fast (0.15) to slow (252.7)
			XFAD	X 0.1 - X 9.9	select the DIM and FCUS construct's crossfade time in increments of 0.1
				X 10 - X166	select the DIM and FCUS construct's crossfade time in increments of 1
			DLAY	D 0.1 - D 9.9	select the delay time in increments of 0.1
				D 10 - D166	select the delay time in increments of 1
			MACR	MCOF	set macro OFF
				MC01 - MC28	select a factory-programmed macro from 1 - 28
				LROF	set Laser Aiming Device (LAD™) OFF <sup>1</sup>
				LRON	set Laser Aiming Device (LAD™) ON continuously <sup>1</sup>
				LM01 - LM30	select a LAD™ strobe speed from slow (4.25 per second - LM01) to fast (255 per second - LM30) <sup>1</sup>
			TIME	SEC	select seconds as the units of time used for the XFAD and DLAY constructs
				MIN	select minutes as the units of time used for the XFAD and DLAY constructs
				HOUR	select hours as the units of time used for the XFAD and DLAY constructs
			ZERO	OK	erase any programming of the current scene by voiding all construct values / mark the end of a loop

Table 3-1. Technobeam Menu Map

Menu Level 1	Menu Level 2	Menu Level 3	Menu Level 4	Menu Level 5	Description
PRST	COPY	FROM	FA01 - FA16		select a scene to copy from (source scene) for user A
			FB01- FB16		select a scene to copy from (source scene) for user B
		TO	TA01 - TA16		select a scene to copy to (destination scene) for user A
			TB01 TB16		select a scene to copy to (destination scene) for user B
	CAPT	SN01 - SN16			select a scene to capture a pre-programmed scene to (from your DMX controller)
	DFLT	OK?			enable the factory-programmed 16 preset scene sequence - erases any preset scenes previously programmed

## Menu Options

The sections below explain how to access the individual menu options shown in the fixture's menu map.

### Address Menu (ADDR)

Use the Address menu to quickly change the current fixture number/DMX start channel. Using this menu option, you can only change the *existing* fixture number to another fixture number, or the *existing* DMX start channel to another DMX start channel.

If you want to change the way you identify the fixture (i.e. change to a fixture number instead of a DMX start channel, or vice versa), complete the procedure described in “Changing the Control Method (CHNL)” on page 3-13.

To change the current fixture number or DMX start channel:

1. Press and hold the <Menu> button until “ADDR” appears on the LED display.
2. Press the <Enter> button to select the “ADDR” menu.

or

3. Use the <Up> and <Down> arrow buttons to select a new DMX start channel (C001 - C512) / fixture number (F 01 - F xx). The LED display will flash when a new option is selected.
4. Press the <Enter> button to accept the new fixture number / DMX start channel. The LED display will stop flashing when a new option is entered. If you do not press the <Enter> button, the new option you selected will not be stored.

**Note** Be sure you do not overlap fixture channel ranges when changing the fixture number/DMX start channel.

# Set Menu (SET)

The Set menu allows you to change the control method from a fixture number to a DMX start channel or vice versa, and either set all factory options to their default settings or change the factory options individually. The procedures below are listed in the order that they appear in the menu map.

## Setting Factory Defaults (FACT)

Technobeam-i fixtures are shipped from the factory with the following preset options set to the following defaults:

- Pan/tilt swap = off
- pan invert = off
- tilt invert = off
- preset playback = off
- LED display = on and bright
- LED display invert = off
- lamp hour warning = off

To return *all* preset options to their factory defaults settings:



5. Press and hold the <Menu> button until “ADDR” appears on the LED display.

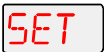

6. Using the <Up> and <Down> arrow buttons, scroll to the “SET” menu and press the <Enter> button to select the “SET” menu.



7. Using the <Up> and <Down> arrow buttons, scroll to the “FACT” menu. (This will be the first menu displayed.) Press the <Enter> button to select the “FACT” menu.

8. Using the <Up> and <Down> arrow buttons, choose “ON” to set the factory option defaults on and press the <Enter> button to select the desired option.\*

**\*Note**

Although “OFF” is an available option in the FACT menu, selecting the “OFF” option will have *no effect* on the individual preset values. To change the value of any of the individual presets listed above, you must access each preset’s corresponding menu item. When you change any of the preset default values individually, this menu item will *automatically* be turned off.

## Swapping Pan and Tilt (SWAP)

To swap the fixture's pan and tilt motion:



1. Press and hold the <Menu> button until "ADDR" appears on the LED display.



2. Using the <Up> and <Down> arrow buttons, scroll to the "SET" menu and press the <Enter> button to select the "SET" menu.



3. Using the <Up> and <Down> arrow buttons, scroll to the "SWAP" menu and press the <Enter> button to select the "SWAP" menu.
4. Using the <Up> and <Down> arrow buttons, choose the "ON" option to swap the fixture's pan and tilt motion, or the "OFF" option to return the fixture's pan and tilt motion to their normal orientation. Press the <Enter> button to select the desired option.

## Inverting Tilt (T/IN)

To invert the direction of the fixture's tilt motion:



1. Press and hold the <Menu> button until "ADDR" appears on the LED display.



2. Using the <Up> and <Down> arrow buttons, scroll to the "SET" menu and press the <Enter> button to select the "SET" menu.



3. Using the <Up> and <Down> arrow buttons, scroll to the "T/IN" menu and press the <Enter> button to select the "T/IN" menu.
4. Using the <Up> and <Down> arrow buttons, choose the "ON" option to invert the fixture's tilt motion, or the "OFF" option to return the fixture's tilt motion to normal orientation. Press the <Enter> button to select the desired option.

## Inverting Pan (P/IN)

To invert the direction of the fixture's pan motion:



1. Press and hold the <Menu> button until "ADDR" appears on the LED display.



2. Using the <Up> and <Down> arrow buttons, scroll to the "SET" menu and press the <Enter> button to select the "SET" menu.



3. Using the <Up> and <Down> arrow buttons, scroll to the "P/IN" menu and press the <Enter> button to select the "P/IN" menu.
4. Using the <Up> and <Down> arrow buttons, choose the "ON" option to invert the fixture's pan motion, or the "OFF" option to return the fixture's pan motion to normal orientation. Press the <Enter> button to select the desired option.

## Changing the Display Output (DSPL)

This menu item allows you to change the appearance of the fixture's alphanumeric LED display. You can set the display on or off, or you can dim the display to reduce visibility.

To change the display output:



1. Press and hold the <Menu> button until “ADDR” appears on the LED display.



2. Using the <Up> and <Down> arrow buttons, scroll to the “SET” menu and press the <Enter> button to select the “SET” menu.

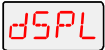

3. Using the <Up> and <Down> arrow buttons, scroll to the “DSPL” menu and press the <Enter> button to select the “DSPL” menu.
4. Using the <Up> and <Down> arrow buttons, choose the “ON” option to set the LED display to normal intensity, the “OFF” option to turn the LED display off, or the “DIM” option to reduce the LED display visibility. Press the <Enter> button to select the desired option.

**Note** If you set the LED display off, the LED display will be turned off only when you exit the menu system.

## Inverting LED Characters (D/IN)

This menu item allows you to invert the orientation of the LED display's alphanumeric characters. This option is useful if your fixture is standing upright (i.e., resting on its bottom panel on the floor).

To invert the LED display:



1. Press and hold the <Menu> button until “ADDR” appears on the LED display.



2. Using the <Up> and <Down> arrow buttons, scroll to the “SET” menu and press the <Enter> button to select the “SET” menu.



3. Using the <Up> and <Down> arrow buttons, scroll to the “D/IN” menu and press the <Enter> button to select the “D/IN” menu.
4. Using the <Up> and <Down> arrow buttons, choose the “ON” option to invert the fixture's alphanumeric characters, or the “OFF” option to return the fixture's alphanumeric characters to normal orientation. Press the <Enter> button to select the desired option.

## Changing the Control Method (CHNL)

Use this menu item if your fixture is currently set to the fixture number control method and instead, you want to use the DMX start channel control method, or vice versa. To simply change an existing fixture number to a different fixture number (or DMX start channel to a different DMX start channel), see “Address Menu (ADDR)” on page 3-10.

To change the control method:

ADDR

1. Press and hold the <Menu> button until “ADDR” appears on the LED display.
2. Using the <Up> and <Down> arrow buttons, scroll to the “SET” menu and press the <Enter> button to select the “SET” menu.
3. Using the <Up> and <Down> arrow buttons, scroll to the “CHNL” menu and press the <Enter> button to select the “CHNL” menu.
4. Using the <Up> and <Down> arrow buttons, choose either the “DMX” option to address the fixture using a DMX start channel, or the “ADDR” option to address the fixture using a fixture number. Press the <Enter> button to select the desired option.

SET

CHNL

DMX

or

ADDR

**Note** After changing the control method, you must assign a specific DMX start channel (C001 - C512) or fixture number (F 01 - F xx) to each fixture (see “Address Menu (ADDR)” on page 3-10).

## Setting the Lamp Warning Message (LMPL)

Use this menu item to enable your fixture to display the warning message “LAMP LIFE ERR” when the current lamp hours exceed 2,000. With this option enabled, after the current lamp hours exceed 2,200 hours, the fixture will display the warning message “LAMP OUT ERR.” Once the lamp is extinguished, the fixture will no longer strike the lamp until the current lamp is replaced and the current lamp hours are reset to zero (see “Replacing the Lamp” on page 6-11 or “Resetting Lamp Hours (L/RS)” on page 3-27).

To enable the lamp warning message:

ADDR

1. Press and hold the <Menu> button until “ADDR” appears on the LED display.
2. Using the <Up> and <Down> arrow buttons, scroll to the “SET” menu and press the <Enter> button to select the “SET” menu.
3. Using the <Up> and <Down> arrow buttons, scroll to the “LMPL” menu and press the <Enter> button to select the “LMPL” menu.
4. Using the <Up> and <Down> arrow buttons, choose the “ON” option to enable the lamp warning message, or the “OFF” option to disable the lamp warning message. Press the <Enter> button to select the desired option.

SET

LMPL

ON

or

OFF

## Changing the Lens Setting (LENS)

Use this menu item if you change the lenses in your fixture. Available lens sets include standard, narrow angle, and wide angle lenses. To obtain a different lens set, contact your High End Systems dealer/distributor.

To change the lens setting:

ADDR

1. Press and hold the <Menu> button until “ADDR” appears on the LED display.

SET

2. Using the <Up> and <Down> arrow buttons, scroll to the “SET” menu and press the <Enter> button to select the “SET” menu.

LENS

3. Using the <Up> and <Down> arrow buttons, scroll to the “LENS” menu and press the <Enter> button to select the “LENS” menu.

NORM

or

WIDE

or

NARW

4. Using the <Up> and <Down> arrow buttons, choose the “NORM” option for standard or narrow angle lenses, the “WIDE” option for wide angle lenses, or the “NARW” option for standard or narrow angle lenses with increased lens tube travel for a greater throw distance.

**Note** The “NARW” option is *not* for use with wide angle lenses.

5. Press the <Enter> button to select the desired option.

## Mode Menu (MODE)

The Mode menu allows you to set the fixture type and protocol and crossload software versions from one fixture to all other Technobeam-i fixtures on the link. The procedures below are listed in the order that they appear on the menu map.

### Setting the Fixture Type and Protocol (TYPE)

Use this menu item to change the fixture type and protocol. The protocol is specific to the fixture and determines the number of DMX channels the fixture will use.

**Note** Although Technopro and Technoray fixtures have been discontinued, their menu options still exist in the protocol.

Available protocols are listed below:

- **TB F** (Technobeam full protocol) - for use with Technobeam fixtures without an iris. This protocol uses 18 DMX channels and is recommended, unless you need to conserve the extra four DMX channels for other devices on the link. The full protocol gives you more control over pan and tilt position and litho spin speed. This protocol allows you to access the Laser Aiming Device™ (LAD) or macros.
- **TB R** (Technobeam reduced protocol) - for use with Technobeam fixtures only. This protocol uses 14 DMX channels. You should use this protocol if you need to conserve the extra four DMX channels for other devices on the link, and your fixtures *do not* have an iris.

- **TR F** (Technoray full protocol) - for use with Technoray fixtures only. This protocol uses 14 channels and is recommended, unless you need to conserve the extra two DMX channels for other devices on the link. The full protocol gives you more control over the rotating litho wheel position and litho spin speed and allows you to access the macros.
- **TR R** (Technoray reduced protocol) - for use with Technoray fixtures only. This protocol uses 12 DMX channels.
- **TPRO** (Technopro protocol) - for use with Technopro fixtures only. This protocol uses 12 DMX channels.
- **TB I** (Technobeam-i protocol) - for use with Technobeam-i fixtures (fixtures with an iris). This protocol uses 18 DMX channels and allows you to access the Laser Aiming Device™ (LAD) or macros.
- **TLCD** (Technopro LCD protocol) - for use with Technopro fixtures controlled with an LCD controller. This protocol uses 18 DMX channels and allows you to access the macros.

To set the fixture type and protocol:

ADDR

1. Press and hold the <Menu> button until “ADDR” appears on the LED display.

MODE

2. Using the <Up> and <Down> arrow buttons, scroll to the “MODE” menu and press the <Enter> button to select the “MODE” menu.

TYPE

3. Using the <Up> and <Down> arrow buttons, scroll to the “TYPE” menu. (This will be the first menu displayed). Press the <Enter> button to select the “TYPE” menu.
4. Using the <Up> and <Down> arrow buttons, choose the desired option (listed above) and press the <Enter> button to select the desired option.\*

**\*Note** This option has a 5-second delay to avoid inadvertent changes. To change the fixture type, you must press and hold the <Enter> button for at least 5 seconds.

## Setting the User Type (USER)

Use this menu item to change the fixture’s user type from user A to user B or vice versa. Each user type includes 16 different presets (scenes) and the following fixture settings:

- Fixture Address
- Pan Invert
- Tilt Invert
- Pan/Tilt Swap
- Control Method (addressing via fixture number or DMX start channel)
- Display Settings (On, Off, or Dim)



- Display Character Invert
- Lamp Warning Message

Changing the user type allows you to access 16 different scenes, and allows you to access a set of “default” fixture settings. For example, if your fixture’s settings (listed above) are designed for a specific location in your truss and you need to move the fixture to a new location, you could change the user type to user “B” for the settings needed at the new location, and change the user type back to user “A” when you move the fixture back to its original location.

To change the user type:

1. Press and hold the <Menu> button until “ADDR” appears on the LED display.

2. Using the <Up> and <Down> arrow buttons, scroll to the “MODE” menu and press the <Enter> button to select the “MODE” menu.

3. Using the <Up> and <Down> arrow buttons, scroll to the “USER” menu and press the <Enter> button to select the “USER” menu.

or

4. Using the <Up> and <Down> arrow buttons, choose the “A” option to select user A settings, or the “B” option to select user B settings. Press the <Enter> button to select the desired option.

## Copying User Presets (PRST)

Use this menu item to copy the fixture’s user preset scenes from user A to user B or vice versa. Each user type includes 16 different presets (scenes) which can be copied to a different user type.

Note                      This options copies *all* 16 presets at one time. To copy an individual scene, see “Copying an On-Board Memory Scene (COPY)” on page 3-29.

To copy user presets:

1. Press and hold the <Menu> button until “ADDR” appears on the LED display.

2. Using the <Up> and <Down> arrow buttons, scroll to the “MODE” menu and press the <Enter> button to select the “MODE” menu.

3. Using the <Up> and <Down> arrow buttons, scroll to the “USER” menu and press the <Enter> button to select the “USER” menu.

4. Using the <Up> and <Down> arrow buttons, scroll to the “COPY” menu and press the <Enter> button to select the “COPY” menu.

5. Using the <Up> and <Down> arrow buttons, scroll to the “PRST” menu and press the <Enter> button to select the “PRST” menu.

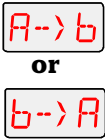

- Using the <Up> and <Down> arrow buttons, choose the “A → B” option to copy user A presets to user B, or the “B → A” option to copy user B presets to user A. Press the <Enter> button to select the desired option.

## Copying User Settings (SETT)

Use this menu item to copy the fixture’s user settings from user A to user B or vice versa. The user settings for each user type are listed in the section titled “Setting the User Type (USER)” on page 3-16.

**Note** This options copies *all* user settings at one time.

To copy user settings:



- Press and hold the <Menu> button until “ADDR” appears on the LED display.



- Using the <Up> and <Down> arrow buttons, scroll to the “MODE” menu and press the <Enter> button to select the “MODE” menu.



- Using the <Up> and <Down> arrow buttons, scroll to the “USER” menu and press the <Enter> button to select the “USER” menu.



- Using the <Up> and <Down> arrow buttons, scroll to the “COPY” menu and press the <Enter> button to select the “COPY” menu.



- Using the <Up> and <Down> arrow buttons, scroll to the “SETT” menu and press the <Enter> button to select the “SETT” menu.

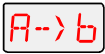

or

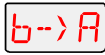

- Using the <Up> and <Down> arrow buttons, choose the “A → B” option to copy user A settings to user B, or the “B → A” option to copy user B settings to user A. Press the <Enter> button to select the desired option.

## Copying User Presets and Settings (ALL)

Use this menu item to copy the fixture’s 16 user presets and fixture settings from user A to user B or vice versa. The user settings for each user type are listed in the section titled “Setting the User Type (USER)” on page 3-16.

**Note** This options copies *all* user settings and *all* 16 presets at one time.

To copy user presets and settings:



- Press and hold the <Menu> button until “ADDR” appears on the LED display.



- Using the <Up> and <Down> arrow buttons, scroll to the “MODE” menu and press the <Enter> button to select the “MODE” menu.



- Using the <Up> and <Down> arrow buttons, scroll to the “USER” menu and press the <Enter> button to select the “USER” menu.

COPY

- Using the <Up> and <Down> arrow buttons, scroll to the “COPY” menu and press the <Enter> button to select the “COPY” menu.

ALL

- Using the <Up> and <Down> arrow buttons, scroll to the “ALL” menu and press the <Enter> button to select the “ALL” menu.

A->b  
or

- Using the <Up> and <Down> arrow buttons, choose the “A → B” option to copy all user A presets and settings to user B, or the “B → A” option to copy all user B presets and settings to user A. Press the <Enter> button to select the desired option.

b->A

## Crossloading Fixture Software (XLD)

If you have a Technobeam-i fixture with a newer software version, you can crossload the newer software to all other Technobeam-i fixtures on the link.

To crossload software:

- Disconnect or bypass any controllers, serial data distributors, data line optoisolators, and any fixtures using RS-422 communications (such as Dataflash® AF1000 xenon strobes, Intellabeam® fixtures, and Emulator® laser simulators). These devices will block communication between your crossloading fixture and any other Technobeam-i fixtures on the link.

ADDR

- On the crossloading fixture *only*, press and hold the <Menu> button until “ADDR” appears on the LED display.

MODE

- Using the <Up> and <Down> arrow buttons, scroll to the “MODE” menu and press the <Enter> button to select the “MODE” menu.

XLD

- Using the <Up> and <Down> arrow buttons, scroll to the “XLD” option and press the <Enter> button to select the “XLD” option.\* The fixture will upload its software to all other Technobeam-i fixtures on the link.

**\*Note** This option has a 5-second delay to avoid inadvertent changes. To crossload fixture software, you must press and hold the <Enter> button for at least 5 seconds.

The Transmit LED on the *crossloading* fixture will remain on (or flicker). The Transmit and Receive LEDs on *receiving* fixtures will flicker while the crossload is in progress, and “UPLD” will appear on the alphanumeric display as each fixture receives the software upload. When the crossload has finished successfully, “DONE” will appear briefly in the LED display of the crossloading fixture, and all other fixtures will home.

**Note** If a new boot code was included with the latest software, the LED will display a “BOOT DIFF” error. To correct the boot code, you must copy the new boot code for each fixture (see “Copying the Boot Code (BOOT)” on page 3-21).

## Test Menu (TEST)

The Test menu allows you to manually home the fixture, turn the lamp on or off, store new boot code information, perform fixture self tests, and place the fixture in setup mode. If you are experiencing problems that you suspect are mechanical, performing fixture self tests will help to determine where the problem originates. The procedures below are listed in the order that they appear on the menu map.

**Note** To see the effects of the self tests, the lamp must be on. If the lamp is off when you run the self test, the LED will display “STRK” to indicate that the lamp is not struck, and the fixture will attempt to strike the lamp automatically.

### Homing the Fixture (HOME)

This menu item allows you to manually home the fixture. If you want to remotely home the fixture (using a DMX controller), use the control channel (DMX channel 18) (see Table 1 on page A-3 or Table 2 on page A-8).

To manually home the fixture:

ADDR

1. Press and hold the <Menu> button until “ADDR” appears on the LED display.

TEST

2. Using the <Up> and <Down> arrow buttons, scroll to the “TEST” menu and press the <Enter> button to select the “TEST” menu.

HOME

3. Using the <Up> and <Down> arrow buttons, scroll to the “HOME” option. (This will be the first option displayed.)
4. Press the <Enter> button to select the “HOME” option. The LED will alternately display “RST” and “HOME” while the fixture homes.

### Turning the Lamp On or Off (LAMP)

You can manually turn the lamp on and off using either the TEST menu or the SET menu.

To manually turn the lamp on or off via the TEST menu:

ADDR

1. Press and hold the <Menu> button until “ADDR” appears on the LED display.

TEST

2. Using the <Up> and <Down> arrow buttons, scroll to the “TEST” menu and press the <Enter> button to select the “TEST” menu.

LAMP

3. Using the <Up> and <Down> arrow buttons, scroll to the “LAMP” menu and press the <Enter> button to select the “LAMP” menu.
4. Using the <Up> and <Down> arrow buttons, choose the “ON” option to strike the lamp, the “OFF” option to extinguish the lamp.

5. Press the <Enter> button to select the desired option.

## Copying the Boot Code (BOOT)

When you upload new software to Technobeam-i fixtures, the new software may contain a new boot code which must be copied to each fixture. This is apparent if the LED displays a “BOOT DIFF” error. *Do not remove power from the fixture while performing a boot copy.* You can copy the new boot code using either the TEST menu or the SET menu.

To accept and store the new boot code using the TEST menu:

Addr

1. Press and hold the <Menu> button until “ADDR” appears on the LED display.

TEST

2. Using the <Up> and <Down> arrow buttons, scroll to the “TEST” menu and press the <Enter> button to select the “TEST” menu.

BOOT

3. Using the <Up> and <Down> arrow buttons, scroll to the “BOOT” option and press the <Enter> button to select the “BOOT” option. The fixture will store the new boot code, then automatically home.

## Performing Self Tests (SELF)

This menu item performs the appropriate self tests for the following:

- ALL - performs all of the self tests listed below
- PAN - moves the pan motor from 0° to 180°
- TILT - moves the tilt motor from 0° to 95°
- COL - tests color wheel movement
- LTO - tests litho wheel movement
- FX - tests effects wheel movement
- FCUS - tests lens tube movement
- IRIS - tests iris movement
- SHUT - tests shutter strobe functions
- DIM - tests shutter dim flag movement

To perform a self test:

Addr

1. Press and hold the <Menu> button until “ADDR” appears on the LED display.

TEST

2. Using the <Up> and <Down> arrow buttons, scroll to the “TEST” menu and press the <Enter> button to select the “TEST” menu.

SELF

3. Using the <Up> and <Down> arrow buttons, scroll to the “SELF” menu and press the <Enter> button to select the “SELF” menu.
4. Using the <Up> and <Down> arrow buttons, scroll to the desired option (listed above). Press the <Enter> button to select the desired option. The fixture will perform the selected self test.
5. Press the <Menu> button to exit the test.

**Note** The self tests will run continuously until you press the <Menu> button to exit the test.

## Placing the Fixture in Setup Mode (S/UP)

This menu item allows you to place the fixture in setup mode so that you can mechanically home your fixture. If the fixture is out of home (i.e., the iris or dim flags lose position), will emit an unusually loud clicking noise when strobing or electronically homing. For more information on how to mechanically home the fixture, contact High End Systems customer service.

To place the fixture in setup mode:

ADDR

1. Press and hold the <Menu> button until “ADDR” appears on the LED display.

TEST

2. Using the <Up> and <Down> arrow buttons, scroll to the “TEST” menu and press the <Enter> button to select the “TEST” menu.

S/UP

3. Using the <Up> and <Down> arrow buttons, scroll to the “S/UP” option and press the <Enter> button to select the “S/UP” option.

4. When the LED displays “SET NOW,” mechanically home the fixture.

5. After mechanically homing the fixture, press any button. This causes the fixture to electronically home.

## Testing the LED Display (DISP)

To perform a self-test on the alphanumeric LED display:

ADDR

1. Press and hold the <Menu> button until “ADDR” appears on the LED display.

TEST

2. Using the <Up> and <Down> arrow buttons, scroll to the “TEST” menu and press the <Enter> button to select the “TEST” menu.

DISP

3. Using the <Up> and <Down> arrow buttons, scroll to the “DISP” option and press the <Enter> button to select the “DISP” option. The LED will run through its self test.

4. Press the <Menu> button to exit the test.

**Note** The self test will run continuously until you press the <Menu> button to exit the test.

## Information Menu (INFO)

The Information menu allows you to view current fixture information such as internal temperature, lamp hours, total fixture hours, lamp strikes, software version, DMX errors, sensor information, and DMX data for any other device on the link. You can also reset the lamp

hours or fixture hours. The procedures below are listed in the order that they appear on the menu map.

## Viewing the Logic Board Temperature (TEMP)

To view the current logic board temperatures:

ADDR

1. Press and hold the <Menu> button until “ADDR” appears on the LED display.

INFO

2. Using the <Up> and <Down> arrow buttons, scroll to the “INFO” menu and press the <Enter> button to select the “INFO” menu.

TEMP

3. Using the <Up> and <Down> arrow buttons, scroll to the “TEMP” option. (This will be the first menu displayed.) Press the <Enter> button to select the “TEMP” option.
4. The LED will display the temperature of the fixture’s logic board in degrees centigrade.

The maximum temperature reading for the logic board is 76° C. If this maximum temperature is exceeded, the fixture’s lamp, LAD, and motors will shut down and the LED panel will display “OVER TEMP.”

## Viewing the Current Lamp Hours (L/HR)

To view the number of hours the lamp has been on since this option was reset:

ADDR

1. Press and hold the <Menu> button until “ADDR” appears on the LED display.

INFO

2. Using the <Up> and <Down> arrow buttons, scroll to the “INFO” menu and press the <Enter> button to select the “INFO” menu.

L/HR

3. Using the <Up> and <Down> arrow buttons, scroll to the “L/HR” option and press the <Enter> button to select the “L/HR” option. The LED will display the number of hours the lamp has been on since this option was reset.

## Viewing the Current Fixture Hours (F/HR)

To view the number of hours the fixture has been on since this option was reset:

ADDR

1. Press and hold the <Menu> button until “ADDR” appears on the LED display.

INFO

2. Using the <Up> and <Down> arrow buttons, scroll to the “INFO” menu and press the <Enter> button to select the “INFO” menu.

F/HR

3. Using the <Up> and <Down> arrow buttons, scroll to the “F/HR” option and press the <Enter> button to select the “F/HR” option. The LED will display the number of hours the fixture has been on since this option was reset.

## Viewing the Number of Current Lamp Strikes (L/ST)

To view the number of times the fixture has attempted to strike (turn on) the current lamp:



1. Press and hold the <Menu> button until “ADDR” appears on the LED display.



2. Using the <Up> and <Down> arrow buttons, scroll to the “INFO” menu and press the <Enter> button to select the “INFO” menu.



3. Using the <Up> and <Down> arrow buttons, scroll to the “L/ST” option and press the <Enter> button to select the “L/ST” option. The LED will display the number of times the fixture has struck the current lamp.

**Note** Lamp strikes are automatically reset when the lamp hours are reset (see “Resetting Lamp Hours (L/RS)” on page 3-27 below).

## Viewing the Current Software Version (VER)

To view the current software version:



1. Press and hold the <Menu> button until “ADDR” appears on the LED display.



2. Using the <Up> and <Down> arrow buttons, scroll to the “INFO” menu and press the <Enter> button to select the “INFO” menu.



3. Using the <Up> and <Down> arrow buttons, scroll to the “VER” option and press the <Enter> button to select the “VER” option. The LED will display the fixture’s current software version.

**Note** The software version is also displayed when you exit the menu system and the normal alphanumeric display cycles between displaying the software version, the fixture name, and the fixture address.

## Viewing DMX Status and Construct Values (FIXT)

This menu option allows you to view DMX status and construct values for the fixture. You should follow this procedure if you are having a particular problem with a fixture; for example, a color wheel that does not respond to commands from the controller.

The following DMX status information is available for viewing:

- BRKS - number of DMX breaks (framing errors with zero data)
- FE - number of framing errors with a non-zero value (errors in data transmission)
- OV - overruns (changing values could indicate data link/connector problems)
- STRT - start code



The following construct values are available for viewing:

- PANH - high 8-bit pan
- PANL - low 8-bit pan
- TLTH - high 8-bit tilt
- TLTL - low 8-bit pan
- COLC - color control channel
- COL - color wheel position
- LTOC - litho control channel
- LTO - litho wheel position
- LTR - litho rotation
- FCUS - lens tube position
- FX - effects wheel position
- FXR - effects wheel rotation
- IRIS - iris position\*
- SHUT - shutter strobe
- DIM - shutter dim flag
- MSPD - MSpeed time
- LAD - Laser Aiming Device\*
- CNTL - control channel

**\*Note** If your Technobeam-i does not have an iris and/or Laser Aiming Device (LAD), the iris and LAD-related constructs will have no functionality.

To view the DMX status and construct values:

A rectangular LED display showing the text "ADDR" in red, outlined characters.

1. Press and hold the <Menu> button until "ADDR" appears on the LED display.

A rectangular LED display showing the text "INFO" in red, outlined characters.

2. Using the <Up> and <Down> arrow buttons, scroll to the "INFO" menu and press the <Enter> button to select the "INFO" menu.

A rectangular LED display showing the text "DMX" in red, outlined characters.

3. Using the <Up> and <Down> arrow buttons, scroll to the "DMX" menu and press the <Enter> button to select the "DMX" menu.

A rectangular LED display showing the text "FIXT" in red, outlined characters.

4. Using the <Up> and <Down> arrow buttons, scroll to the "FIXT" menu and press the <Enter> button to select the "FIXT" menu.
5. Using the <Up> and <Down> arrow buttons, scroll to the desired DMX status or construct (listed above) and press the <Enter> button to select the desired option. The LED will display the selected DMX status or construct value.

If you are having a particular problem with the fixture, follow the steps above to select a construct and view its value. After noting the value of the construct you selected, use your controller to change that construct's value.

If the value changes on the fixture's LED display, but the fixture still does not respond, contact High End Systems customer service.

However, if the value does not change on the fixture's LED display, remove the fixture from the DMX link and try to change the construct's

value using the fixture's menu system. If the fixture then functions normally, the problem was likely with the DMX link. Otherwise, contact High End Systems customer service.

## Viewing DMX Data for Another Device (DATA)

This procedure allows you to use an Technobeam-i fixture to view DMX channel values for other devices on the DMX link. You should use this procedure either for testing devices that do not have built-in DMX diagnostics, or for fixtures that are physically inconvenient to monitor directly.

**Note** You can only view DMX channel values for devices which have a channel range less than the viewing fixture's channel range.

To view DMX data for another device on the DMX link:



1. Press and hold the <Menu> button until "ADDR" appears on the LED display.



2. Using the <Up> and <Down> arrow buttons, scroll to the "INFO" menu and press the <Enter> button to select the "INFO" menu.



3. Using the <Up> and <Down> arrow buttons, scroll to the "DMX" menu and press the <Enter> button to select the "DMX" menu.



4. Using the <Up> and <Down> arrow buttons, scroll to the "DATA" menu and press the <Enter> button to select the "DATA" menu.



to



5. Using the <Up> and <Down> arrow buttons, scroll to the desired DMX channel (C001 - C512) and press the <Enter> button to select the desired DMX channel. The LED will display the selected channel's DMX value.

If you are experiencing a particular problem with a device on the link, follow the steps above to select a DMX channel in the device's channel range and view its DMX value. After noting the value of the channel you selected, use your controller to change that channel's value.

If the value of the DMX channel you selected does not change, there may be a problem with the DMX cable or your transmitting device (i.e. controller).

However, if the DMX channel value changes, but the device does not respond, the device may be faulty. Consult the documentation provided with that device for more information.

## Viewing Sensor Information (SENS)

This menu option allows you to view whether a specified sensor is working correctly. If you receive a "SENS ERR" error message on the alphanumeric LED display, this information may help you determine where the problem originates.

The following sensor information is available:

- LTR - view whether the litho rotate (within the wheel) sensor is obstructed (“OFF”) or is not obstructed (“ON”)
- LTO - view whether the litho wheel sensor is obstructed (“OFF”) or is not obstructed (“ON”)
- COLR -view whether the color wheel sensor is obstructed (“OFF”) or is not obstructed (“ON”)
- FX - view whether the effects wheel sensor is obstructed (“OFF”) or is not obstructed (“ON”)

To view the specified sensor information:

ADDR

1. Press and hold the <Menu> button until “ADDR” appears on the LED display.

INFO

2. Using the <Up> and <Down> arrow buttons, scroll to the “INFO” menu and press the <Enter> button to select the “INFO” menu.

SENS

3. Using the <Up> and <Down> arrow buttons, scroll to the “SENS” menu and press the <Enter> button to select the “SENS” menu.

4. Using the <Up> and <Down> arrow buttons, scroll to the desired option (listed above) and press the <Enter> button to select the desired option to view its sensor information.

## Resetting Fixture Hours (F/RS)

This menu item allows you to track the number of hours the fixture has been operating.

To reset the fixture hours to zero:

ADDR

1. Press and hold the <Menu> button until “ADDR” appears on the LED display.

INFO

2. Using the <Up> and <Down> arrow buttons, scroll to the “INFO” menu and press the <Enter> button to select the “INFO” menu.

F/RS

3. Using the <Up> and <Down> arrow buttons, scroll to the “F/RS” option and press the <Enter> button to select the “F/RS” option\*. The LED will display “0000” when the fixture hours are reset.

**\*Note** This option has a 5-second delay to avoid inadvertent changes. To reset the fixture hours, you must press and hold the <Enter> button for at least 5 seconds.

## Resetting Lamp Hours (L/RS)

This menu item allows you to track the number of hours the lamp has been operating. You should reset the lamp hours every time you change the lamp.

To reset the current lamp hours to zero:

ADDR

1. Press and hold the <Menu> button until “ADDR” appears on the LED display.
2. Using the <Up> and <Down> arrow buttons, scroll to the “INFO” menu and press the <Enter> button to select the “INFO” menu.
3. Using the <Up> and <Down> arrow buttons, scroll to the “L/RS” option and press the <Enter> button to select the “L/RS” option\*. The LED will display “0000” when the lamp hours are reset.

INFO

L/RS

**\*Note** This option has a 5-second delay to avoid inadvertent changes. To reset the lamp hours, you must press and hold the <Enter> button for at least 5 seconds.

## Preset Menu (PRST)

The Preset menu allows you to turn preset playback off or on, view which scene is currently playing, and create/edit a scene using the on-board memory to program the fixture for stand-alone operation. This menu also allows you to copy a scene within the fixture’s on-board memory, capture a scene from your DMX controller to the fixture’s on-board memory, and enable the fixture’s factory-programmed preset sequence (self demo).

## Setting Preset Playback (PLAY)

This menu option allows you to turn preset playback on or off and view which scene is currently playing in preset playback mode.

To set preset playback on or off, or to view the current scene:

ADDR

1. Press and hold the <Menu> button until “ADDR” appears on the LED display.
2. Using the <Up> and <Down> arrow buttons, scroll to the “PRST” menu. Press the <Enter> button to select the “PRST” menu.
3. Using the <Up> and <Down> arrow buttons, scroll to the “PLAY” menu. (This will be the first option displayed). Press the <Enter> button to select the “PLAY” menu.
4. Using the <Up> and <Down> arrow buttons, scroll to the “ON” option to set preset playback on, the “OFF” option to set preset playback off, or the “SCN” option to display which scene is currently playing. Press the <Enter> button to select the desired option.

PRST

PLAY

**Note** Scene 1 *must* be programmed before the fixture can play back scenes.

## Editing or Creating an On-Board Memory Scene (EDIT)

This menu item allows you to edit or create a scene using the fixture's on-board scene memory. Using this menu option, you can change the value of any construct in any of the on-board scenes. For detailed information on editing or creating a scene, see Chapter 4.

To edit/create a scene:

1. Press and hold the <Menu> button until "ADDR" appears on the LED display.
2. Using the <Up> and <Down> arrow buttons, scroll to the "PRST" menu and press the <Enter> button to select the "PRST" menu.
3. Using the <Up> and <Down> arrow buttons, scroll to the "EDIT" menu and press the <Enter> button to select the "EDIT" menu.
4. Using the <Up> and <Down> arrow buttons, scroll to the scene ("SN01" to "SN16") that you want to edit or create and press the <Enter> button to select the desired scene.

## Copying an On-Board Memory Scene (COPY)

1. Press and hold the <Menu> button until "ADDR" appears on the LED display.
2. Using the <Up> and <Down> arrow buttons, scroll to the "PRST" menu and press the <Enter> button to select the "PRST" menu.
3. Using the <Up> and <Down> arrow buttons, scroll to the "COPY" menu and press the <Enter> button to select the "COPY" menu.
4. The LED will display "FROM." Press the <Enter> button to enter the "FROM" menu.
5. Using the <Up> and <Down> arrow buttons, scroll to the scene that you want to copy from (source scene) for either user A ("FA01" - "FA16") or user B ("FB01" - "FB16"). Press the <Enter> button to select the desired scene.
6. The LED will display "TO." Press the <Enter> button to enter the "TO" menu.
7. Using the <Up> and <Down> arrow buttons, scroll to the scene that you want to copy to (destination scene) for either user A ("TA01" - "TA16") or user B ("TB01" - "TB16"). Press the <Enter> button to select the desired scene.

The fixture will copy the desired scene to the selected scene location. When the fixture finishes the copy successfully, "DONE" will appear briefly in the fixture's LED display.

## Capturing a Preset Scene (CAPT)

Preset capturing is a way to automate the creation of scenes on multiple Technobeam-i fixtures connected to a DMX 512 link. Use a

DMX controller to create a scene, then save (capture) the scene into a fixture's presets to play back the scene without the controller.

After creating a scene with your DMX controller, follow the instructions below for each fixture on which you want to capture preset scenes:

ADDR

1. Press and hold the <Menu> button until "ADDR" appears on the LED display.

PRST

2. Using the <Up> and <Down> arrow buttons, scroll to the "PRST" menu and press the <Enter> button to select the "PRST" menu.

CAPT

3. Using the <Up> and <Down> arrow buttons, scroll to the "CAPT" menu and press the <Enter> button to select the "CAPT" menu.

SNO1

4. Using the <Up> and <Down> arrow buttons, scroll to the scene you want to copy the preset scene to (destination scene) and press the <Enter> button.

to

SNI6

Pressing the <Enter> button will copy the DMX-512 controller's preset scene to the selected scene on your fixture's on-board 16 scene memory. When the fixture finishes the capture successfully, "DONE" will appear briefly in the fixture's LED display.

**Note** You must use the fixture's on-board scene memory to *manually* select values for the XFAD, DLAY, and TIME constructs, since a DMX controller will not transmit those construct values. For more information on using the fixture's on-board scene memory, refer to the *Technobeam® User Manual*.

## Enabling the Preset Default (DFLT)

This menu item enables the factory-programmed 16 preset sequence or fixture self demo. Enabling this menu item will *erase any pre-programmed scenes* or construct values on your fixture's on-board memory for either user A or user B.

To enable the self-demo:

ADDR

1. Press and hold the <Menu> button until "ADDR" appears on the LED display.

PRST

2. Using the <Up> and <Down> arrow buttons, scroll to the "PRST" menu and press the <Enter> button to select the "PRST" menu.

dFLT

3. Using the <Up> and <Down> arrow buttons, scroll to the "DFLT" menu and press the <Enter> button to select the "DFLT" menu. The LED display will show "OK?"

4. Press the <Enter> button to enable the self-demo or press <Menu> to exit the menu option.

**Note** To play the fixture's self-demo, you must set preset playback on (see "Setting Preset Playback (PLAY)" on page 3-28).

# Chapter 4

## Preset Programming

Programming Overview .....	4-2
What is a “Scene”? .....	4-2
Stand-alone Operation vs. a Controller .....	4-2
Macros .....	4-2
Preset Playback Options .....	4-3
General Information .....	4-3
Subject to Change .....	4-3
Enter and Menu Keys .....	4-3
MSpeed vs. Fast Changes .....	4-3
Selecting Constructs and Values .....	4-4
Creating a Scene .....	4-4
Orienting and Powering On the Fixture .....	4-4
Turning on the Lamp .....	4-4
Opening the Shutter .....	4-5
Positioning the Mirror .....	4-6
Focusing on a Litho .....	4-6
Selecting Color Wheel Constructs .....	4-6
Selecting a Color Wheel Pause Time .....	4-7
Selecting Effects Constructs .....	4-7
Refocusing the Fixture .....	4-7
Setting a Delay Time .....	4-7
Creating Scene 2 .....	4-8
Playing Back Both Scenes .....	4-8
Synchronizing Preset Playback .....	4-9
Setting Up the Fixtures .....	4-9
Adding Fixtures .....	4-11
Capturing Presets .....	4-11

# Programming Overview

---

This chapter explains how to create and play back scenes using the fixture's onboard 16-scene memory, and has a step-by-step example. More information about preset programming can be found on the *Technobeam Quick Reference Card* (p/n 60600109, v1.0 or later).

## What is a “Scene”?

A *scene* (which can also be called a *page* or *look*) is a combination of the constructs you configure. A *construct* is a unique fixture feature—for example, focus, color or rotating effects. Each scene consists of all of the constructs you select; you can make each scene as simple or complex as you want.

When you play back more than one scene in sequence, it becomes a *program* (also called a *show*). A program or show that continuously repeats is called a *loop* or a *chase*.

Technobeam fixtures always play back all contiguously-programmed scenes in a continuous loop. The loop plays back until you either turn the fixture off or stop scene playback. You must create the scenes contiguously (in other words, scene 1, scene 2, scene 3, scene 4, and so on without skipping a scene) because the fixture automatically repeats when it encounters the first unprogrammed scene or when all available scenes are programmed.

## Stand-alone Operation vs. a Controller

You can use a controller or control device (such as DMX control software), or onboard memory to create and play back scenes, but not both at the same time.

In other words, you cannot create a scene using the fixture's onboard memory and play it back using a controller. You also cannot use a controller at the same time onboard scenes are playing back.

You can create up to sixteen scenes using a controller and copy the scenes to the fixture's onboard memory. However, XFAD and DLAY construct values cannot be copied this way, so you must manually (using preset programming) enter values for these two constructs.

## Macros

Each Technobeam fixture has 28 selectable *macros*. A macro is a factory-programmed set of fixture constructs picked for their ability to achieve a dramatic and exciting effect. Using a macro can help you save time while programming your fixture.

**Note** You must select the full protocol for the fixture to use macros.



# Preset Playback Options

Technobeam offers the following two options for use with preset programming:

- **Preset capture:** Use any DMX 512-compatible controller to create a scene(s) that can then be saved into the fixture's own presets and later recalled in stand-alone operation without the controller. The only constructs that *cannot* be captured in this way are crossfade (XFAD) and delay (DLAY); you must configure them manually on each fixture.
- **Synchronized preset playback:** Use one fixture to synchronize playback among all fixtures on the link. One fixture must be configured as fixture number 1 or at DMX start channel 1. No controllers can be attached to the link containing the synchronized fixtures. See the section titled "Synchronizing Preset Playback" on page 4-9 for more information.

## General Information

This section lists general points you need to keep in mind while you are creating and playing back scenes on the fixture.

### Subject to Change

The information in the following sections is based on what was available at the time this manual went to print; however, all information—particularly constructs and construct values—is subject to change.

### Enter and Menu Keys

Whenever you are creating a scene, the <Enter> key *accepts* the current selection, whether that selection is a construct—such as SHUT for the shutter—or a value for a construct, such as OPEN. Each construct value is automatically saved when you press <Enter>.

The <Menu> key moves you back to the previous option or menu *without changing* a value.

### MSpeed vs. Fast Changes

Some constructs allow you to choose either fast position selection or position selection set by MSpeed (motor/mirror speed).

A *fast* change means the position selection is completed in the shortest length of time after the wheel starts moving.

An *MSpeed* (motor/mirror speed) change occurs smoothly over the entire MSpeed time value. A table of MSpeed times is shown in Appendix A of the user manual.

## Selecting Constructs and Values

The step-by-step example in the next section suggests particular constructs and values that will give you an idea of how the fixture works. You can choose different constructs or values using the information in Appendix E.

## Creating a Scene

---

This step-by-step example involves the following basic steps:

- Positioning and powering on the fixture
- Turning on the lamp
- Opening the shutter
- Focusing on a litho
- Selecting color and effects options
- Enabling preset playback

## Orienting and Powering On the Fixture

1. Orient (physically position) the fixture so the light will be projected onto a flat, light-colored object such as a white wall or ceiling. If you have Technobeam, you will be able to move the mirror to a suitable position.
2. Follow the instructions in Chapter 1 to connect the fixture to an appropriately-rated power outlet, if you have not already done so. (There is no power switch.) Wait for the fixture to finish homing (the gears and motors stop moving).

## Turning on the Lamp



1. Press and hold the <Menu> key until **ADDR** appears in the LED display.

**Note** If you are already in the menu system, keep pressing (but do not hold down) the <Menu> key until **ADDR** is displayed.

If **MENU** is displayed, press the <Enter> key to view the **ADDR** option.



2. Use the <Up> and <Down> arrow keys to navigate to the **TEST** menu.



3. Press <Enter>, then use the <Up> and <Down> arrow keys to navigate to the **LAMP** option.

ON

4. Press <Enter>, then use the <Up> and <Down> arrow keys to select **ON**.
5. Press <Enter>. The lamp is now ON, although it might not be visible if the dim flags (also called *shutter* or *light gate*) are closed.

## Opening the Shutter

ADDR

1. Press and keep pressing the <Menu> key until **ADDR** appears in the LED display.

PRST

2. Use the <Up> or <Down> arrow keys to navigate to the **PRST** menu.

EDIT

3. Press <Enter>, then use the <Up> or <Down> arrow keys to select **EDIT**.

SCN1

4. Press <Enter>; the LED display shows **SCN1** option, indicating you are now creating scene number 1. The procedure that follows does not cover every available construct because each fixture is slightly different.

5. Press <Enter> to begin creating scene 1.

6. If you can see light exiting the fixture, the shutter is already open; skip to the next section.

SHUT

7. Use the <Up> and <Down> arrow keys to navigate to the **SHUT** construct.

OPEN

8. Press <Enter>, then press the <Up> and <Down> arrow keys to select **OPEN**.

9. Press <Enter>; light should now be visible through the aperture. If so, see the next section.

10. If no light is visible through the aperture, either the shutter is still closed or the lamp is not on. First look through the aperture (*at an angle, not directly*) and make sure the two black dim flags are open, as shown in Figure 4-1. (The two dim flags act as both the dimming mechanism and as the shutter.)

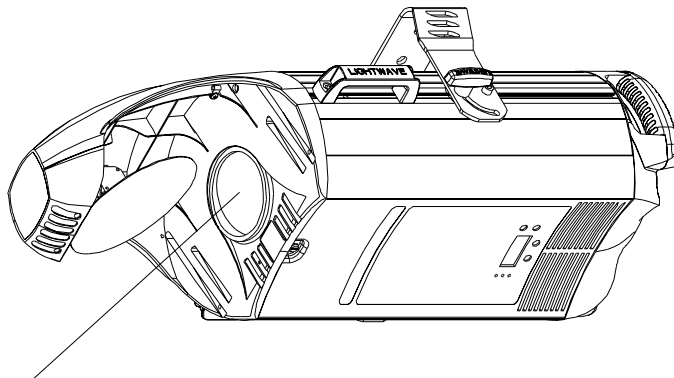

Aperture (dim flags are barely visible at edges when shutter is open)

Figure 4-1. Making sure the shutter is open.

11. If the flags are closed, repeat this procedure.
12. If the shutter is open and no light is exiting the fixture, the lamp is off. (The lamp is automatically turned off after a period of no activity.) In that case, turn the fixture OFF, wait a few minutes, then repeat the procedure in the section titled “Turning on the Lamp” on page 4-4.

## **Positioning the Mirror**

PAN

1. Use the <Up> and <Down> arrow keys to navigate to the **PAN** construct.
2. Use the <Up> and <Down> arrow keys to move the mirror to the desired location, then press <Enter>.

TILT

3. Use the <Up> and <Down> arrow keys to navigate to the **TILT** construct and press <Enter>.
4. Use the <Up> and <Down> arrow keys to move the mirror to the desired location, then press <Enter>.

## **Focusing on a Litho**

LTOC

1. Use the <Up> and <Down> arrow keys to navigate to the **LTOC** (control) construct.

IDX

2. Press <Enter>, then use the <Up> and <Down> arrow keys to select **IDX**.

LTO

3. Press <Enter> to accept your selection, then use the <Up> and <Down> arrow keys to navigate to the **LTO** construct.
4. Press <Enter>, then press the <Up> or <Down> arrow keys to select any litho pattern (except **L 1**, the open position).

FCUS

5. Press <Enter> to accept your selection, then use the <Up> and <Down> arrow keys to navigate to the **FCUS** construct.
6. Press <Enter>, then use the <Up> and <Down> arrow keys to bring the litho into sharp focus.
7. Press <Enter> when you are finished focusing the fixture.

## **Selecting Color Wheel Constructs**

COLC

1. Use the <Up> and <Down> arrow keys to select **COLC**.

RND

2. Press <Enter>, then press the <Up> and <Down> arrow keys to select **RND** (random color selection).
3. Press <Enter>. The color wheel spins and stops on a random position, pausing for a length of time you will set in the next section.

## Selecting a Color Wheel Pause Time

COL

1. Use the <Up> and <Down> arrow keys to navigate to the **COL** construct.
2. Press <Enter>, then use the <Up> and <Down> arrow keys to select a pause time (the higher the value, the longer the pause time).
3. Press <Enter> to accept your selection.

## Selecting Effects Constructs

FX

1. Use the <Up> and <Down> arrow keys to navigate to the **FX** construct.
2. Press <Enter>, then use the <Up> and <Down> arrow keys to select any effects position other than **FX 1** (open).

FXR

3. Press <Enter>, then use the <Up> and <Down> arrow keys to navigate to the **FXR** construct.
4. Press <Enter>, then use the <Up> and <Down> arrow keys to select either a forward or reverse rotation speed.
5. Press <Enter> to save your settings.

## Refocusing the Fixture

If you selected the suggested constructs, you should now see a litho pattern being changed by a rotating effect and random color changes. This section shows how you can use the fixture's superior optics to refocus the image.

FCUS

1. Use the <Up> and <Down> arrow keys to navigate to the **FCUS** construct.
2. Press <Enter>, then use the <Up> and <Down> arrow keys to change the focus. You can focus on the effects wheel, the litho wheel, the color wheel or anywhere in between.
3. Press <Enter> when you are done.

## Setting a Delay Time

The **DLAY** construct determines the length of time scene 1 “plays” before the next scene begins.

DLAY

1. Use the <Up> and <Down> arrow keys to navigate to the **DLAY** construct.
2. Press <Enter>, then use the <Up> and <Down> arrow keys to select a value of **3.0**. This means that scene 1 will “play” for 3 seconds before moving on to scene 2. (You will not see the effect of the **DLAY** construct until you play back your programmed scenes.)

3. Press <Enter> to save your setting.

**Note** The default unit of time is seconds, but you can change the units to either minutes or hours using the **TIME** construct on the PRST menu.

## Creating Scene 2

This section shows how to use the convenient scene copy feature to copy constructs and values from scene 1 to scene 2. Scene copy can greatly speed up the time required to program the fixture, especially for scenes that have minor variations in construct values.

1. Keep pressing the <Menu> key to navigate to the **PLAY** option. (The dim flags close when you make this selection, so you will not see any light exiting the fixture; *this is normal*).
2. Use the <Up> and <Down> arrow keys to select **COPY**.
3. Press <Enter>; the display then shows **FROM**.
4. Press <Enter> and select the scene to copy from. The default option is the current scene number. (**FOO1** indicates you will copy from scene 1.)
5. Press <Enter> to select scene 1 to copy from. The display then shows **TO**.
6. Press <Enter>; the LED display shows the previously-selected scene number. Use the <Up> and <Down> arrow keys to select **T002** (scene 2).
7. Press <Enter> to select scene 2; the LED display shows **COPY**.
8. Press <Enter>. The constructs are copied from scene 1 to scene 2.
9. Keep pressing the <Menu> key to navigate to the **PLAY** option.
10. Use the <Up> and <Down> arrow keys to select **EDIT**.
11. Press <Enter>, then use the <Up> and <Down> arrow keys to select **SCN2**.
12. Press <Enter> and change the **DLAY** construct to a value of **1.0**.
13. Press <Enter> to accept your selection. Make other construct changes, if desired (if you have Technobeam, move the mirror to a different location using the PAN and TILT constructs.)

## Playing Back Both Scenes

Turning preset playback ON starts all programmed scenes playing back in a continuous loop. Scenes advance at the rate set by the DLAY construct and continue playing back until you turn preset playback OFF.

If preset playback was enabled when you powered the fixture OFF, preset playback restarts automatically when you power the fixture back ON again. You can disable preset playback at any time by selecting **OFF** from the PLAY menu.

- PLAY**
1. Keep pressing the <Menu> key until **PLAY** appears in the LED display. (The Play option allows you to turn preset playback on and off.) The dim flags close when you make this selection, so you will not see any light exiting the fixture; *this is normal*.
- ON**
2. Press <Enter>, then use the <Up> and <Down> arrow keys to select **ON**.
  3. Press <Enter> to start preset playback.
  4. Your scene(s) start playing back, starting with scene 1, continuing to the first unprogrammed scene, then returning to scene 1, etc. The LED display should look similar to the one below:

Dot indicates preset playback is on



Figure 4-2. A dot always appears in the LED display whenever preset playback is on.

- PLAY**
5. To turn preset playback off, keep pressing the <Menu> key to select the **PLAY** option and press <Enter>.
- OFF**
6. Use the <Up> and <Down> arrow keys to select **OFF** and press <Enter>. That stops preset playback, but leaves the currently-running scene active. Select an unprogrammed scene to return the fixture to its default state (with no scene active).

## Synchronizing Preset Playback

---

Once you have programmed one or more scenes for your Technobeam fixtures and connected them to a DMX 512 link, you can synchronize preset playback from one fixture as described in this section.

**Note** Do not put a controller on the DMX 512 link if you want to use synchronized preset playback.

## Setting Up the Fixtures

Make sure you do all of the following when you set up the link. More information about setting up a DMX 512 link is shown in Chapter 2.

1. One fixture must be set as fixture number 1 or at DMX start channel 1 as described in Chapter 2. *Make sure no other fixture on the link is configured as fixture number 1 or at DMX start channel 1.*
2. The fixture in Step 1 should be physically the first fixture in the link, as shown in Figure 4-3. The last fixture in the link must be terminated.
3. You can choose any fixture number or DMX start channel you want for any of the other fixtures on the link. For example, fixture number 2 does not have to be directly connected to fixture number 1.
4. Make sure there are no controllers on the link.
5. Enable preset playback for all fixtures on the link.

**Note** After you enable preset playback on the fixture you configured as fixture 1 or DMX start channel 1, the Transmit LED on that fixture will continue flickering yellow until you disable preset playback.

6. The total delay time of all the scenes on the first fixture (fixture number 1 or DMX start channel 1) should be *longer* than the total delay time of all the scenes on any other fixture in the link. Otherwise, not all scenes on all fixtures will finish playing before looping back to scene 1.

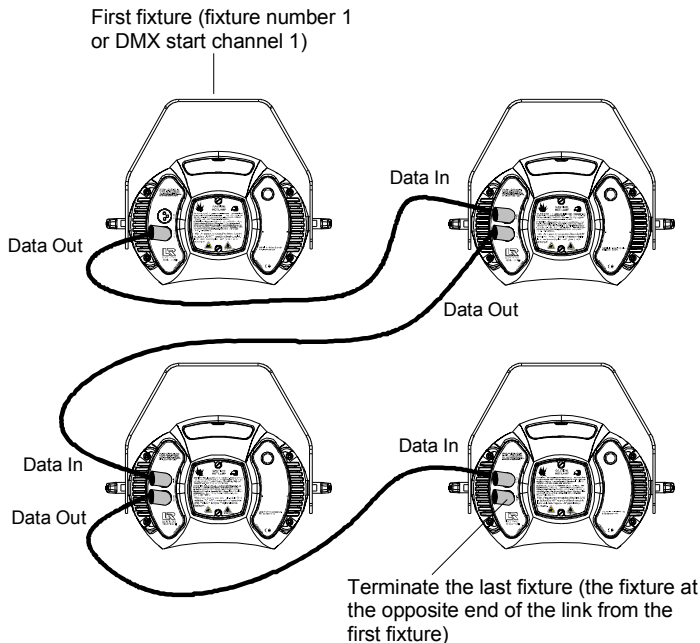

*Figure 4-3. When you set up fixtures for synchronized playback on a DMX 512 link, one and only one fixture **must be** fixture number 1 or DMX start channel 1. The last fixture on the link must be terminated.*



## Adding Fixtures

Once you have started synchronized preset playback on the link, you can add other fixtures to the link anytime you want. A fixture added after synchronized preset playback has begun will start playing the scene most closely matching the timeline set by the first fixture. (It will not necessarily begin with scene 1, and it might begin in the middle of a scene.)

When the first fixture wraps to scene 1, the added fixture also wraps to scene 1 and continues playing its scenes normally according to the scenes' delay times.

## Capturing Presets

---

Preset capturing is a way to automate the creation of scenes on multiple Technobeam fixtures connected to a DMX 512 link. You use a DMX 512-compatible controller to create a scene, save (*capture*) the scene into a fixture's presets and later play back the scene without the controller.

This procedure assumes you are already familiar with your controller; if not, consult the controller's documentation. It also assumes you have some familiarity with using the menu system on Technobeam; if not, review Chapter 3 and this chapter.

1. Connect a DMX 512 controller and Technobeam fixtures on a DMX 512 link as described in Chapter 2.
2. Make sure all Technobeam fixtures are configured for their respective full protocols (see "Fixture Types" on page 2-13). Selecting the full protocol takes advantage of all constructs available for the fixture type.
3. Create a scene on the controller. The DMX protocols for Technobeam are listed in Appendix A.
4. Make sure all construct values on the controller are constant. There cannot be any mirror movement or scene-to-scene sequencing.
5. Go to the first fixture you want to store the scene on.
6. Navigate to the **PRST** menu.
7. Press <Enter>, then use the <Up> and <Down> arrow keys to navigate to the **CAPT** option.
8. Press <Enter>, then use the <Up> and <Down> arrow keys to select a scene to capture to. If you select **SCN2**, as shown, you will capture DMX data from the controller into the fixture's scene 2.

PRST

CAPT

SCN2

9. Press <Enter>. The scene created on the controller is now stored in the selected scene number.
10. You will need to manually select values for the XFAD and DLAY constructs, since the controller does not transmit those constructs.

**Note** If the scene you captured to was previously programmed, you will need to make that scene active in order to view the newly-captured scene for the first time. (To make the scene active, select the scene number from the **EDIT** menu.)

11. Repeat the procedure for each fixture you want to capture presets to.

# Chapter 5

## Using the Laser Aiming Device<sup>®</sup> (LAD<sup>®</sup>)



Safety Precautions .....	5-2
Overview .....	5-3
Recommended Laser Operation .....	5-3
Intended Audience .....	5-3
Using the Laser Aiming Device .....	5-3
Controlling the Laser .....	5-5
Menu Control of the Laser .....	5-5
DMX Control of the Laser .....	5-5
Troubleshooting .....	5-6
Laser gradually loses power .....	5-6
Laser is out of position .....	5-6
Emission Indicator LED OFF, Laser OFF .....	5-6
Emission Indicator LED ON, Laser OFF .....	5-7
Laser ON, Emission Indicator LED OFF .....	5-8
Maintenance .....	5-8

# Safety Precautions

This section lists precautions you must follow anytime you are using the Laser Aiming Device™ (LAD™) for Technobeam.

1. CAUTION: Use of controls or adjustments or performance of procedures other than those specified herein may result in hazardous radiation exposure.
2. Using the Laser Aiming Device with any fixture other than Technobeam may result in damage to both the laser and the fixture as well as exposure to laser radiation.
3. Do not point the laser at an audience.
4. Precautions should be taken to ensure that the laser beam is not unintentionally directed at mirror-like (specular) surfaces (most importantly, at flat mirror-like surfaces).
5. Only qualified and trained employees approved by a laser safety officer should be assigned to install, adjust and operate the laser equipment.
6. When not in use, the laser (fixture) should be stored in a location where unauthorized personnel cannot gain access.
7. *Do not remove* the labels shown at the bottom of this page; they are required by U.S. and European safety agencies.
8. Areas in which this product is used should be posted with a standard laser warning sign.
9. Do not stare directly into the beam and do not view the beam with optical instruments.
10. The laser path should be located well above or below eye level.
11. The laser beam should be terminated at the end of its useful path.
12. Consult local and state laws regarding laser use and possible registration requirements.

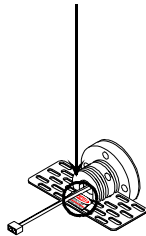

Laser aiming device assembly  
(inside fixture)

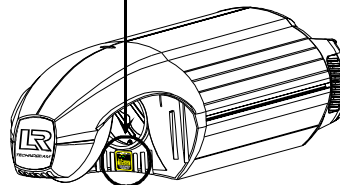

# **Overview**

---

The Technobeam LAD makes it easy for you to position the mirror during daylight or high ambient light conditions. This in turn allows you the additional flexibility to set up or verify mirror preset positions in conditions that would otherwise make positioning difficult or impossible.

## **Recommended Laser Operation**

The most effective and efficient way to use the laser aiming device is with the fixture's lamp off and dim flags (shutter) closed. There are three reasons for this:

- The higher the temperature, the shorter the life of the laser aiming device. Keeping the lamp off minimizes the temperature inside the fixture, extending the life of the laser.
- The higher the temperature, the less bright the laser will be. If the fixture operates (with the lamp on) at 40°C (104°F) for example, laser power will be decreased by about 25%.
- Technobeam was designed so the laser light can exit the fixture with the dim flags (shutters) closed or completely open. At certain intermediate dim flag positions, the laser light might be partially blocked.

## **Intended Audience**

Only qualified and trained employees approved by a laser safety officer should be assigned to install, adjust and operate the laser equipment.

## **Using the Laser Aiming Device**

You can control the laser using either the fixture's onboard programs, the Technobeam LCD controller, or any DMX 512-compliant controller as shown in the section titled "Controlling the Laser" on page 5-5.

The laser exits the fixture through the same aperture as the light beam, as shown in Figure 5-1. Technobeam was designed so that the laser is visible if the dim flags are completely closed or open.

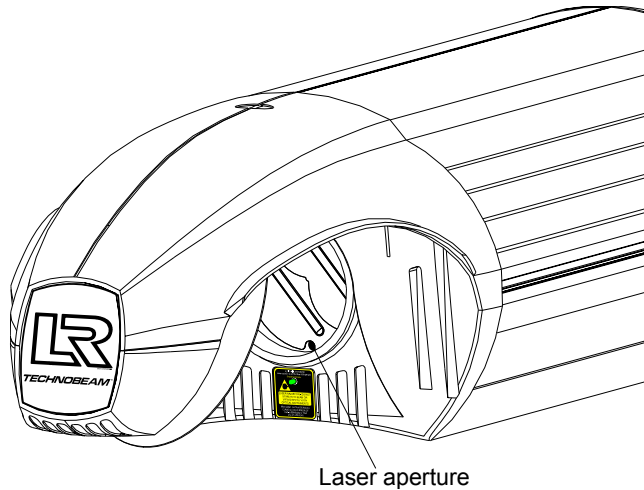

*Figure 5-1. The laser light exits through the same aperture as the light beam.*

The laser should ideally be no more than 2" (5 cm) directly above the center point of a perfectly round light beam, as shown in Figure 5-2:

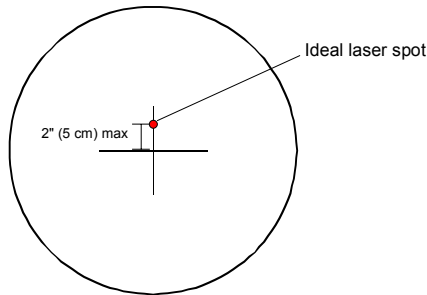

*Figure 5-2. The ideal position of the laser is no more than 2" (5 cm) directly above the center point of a perfectly round light beam.*

In its ideal position, the laser path is parallel to the path of the light and will stay 2" (5 cm) above the center point of the beam at any throw distance or mirror position.

If the laser becomes out of position, you might need to align it as shown in the section titled "Technobeam Laser Aiming Device™" on page 6-19.

However, the decision of whether or not to align the laser is entirely up to you. If the laser strays from its optimal position, but it gives you enough accuracy for your needs, you do not *have to* align it.

# Controlling the Laser

---

You can control the laser in one of three ways:

- **The fixture's menu system:** Edit one of the fixture's sixteen onboard presets (scenes) using the PRST menu as described in the next section.
- **Any DMX 512-compliant controller:** See the section titled "DMX Control of the Laser" on page 5-5.
- **The Technobeam LCD controller:** See the controller's user manual.

## Menu Control of the Laser

Use the PRST menu to create scenes (presets) including the laser aiming device. You access the LAD using the **MACR** construct from the PRST menu.

The complete list of options controlling the laser aiming device (with the MACR construct) is shown below:

- **LROF:** laser aiming device OFF
- **LRON:** laser aiming device ON continuously
- **LM01 to LM30:** laser modulation levels. **LM01** is "slow" modulation at 4.25 times/sec and **LM30** is "fast" modulation at 255 times/sec.

## DMX Control of the Laser

This section explains how to control the laser using a DMX 512-compatible controller.

1. Select a fixture number or DMX start channel for each fixture you wish to control as described in Chapter 2.
2. Make sure you select the Technobeam full 18-channel protocol (**TBF** from the Mode menu); otherwise, the laser aiming device will not function.
3. Connect the fixtures to the controller as described in Chapter 2.
4. See Appendix A for details of DMX 512 control (see in Table A-1 on page A-3 or Table A-2 on page A-8).

# Troubleshooting

---

If laser fails to illuminate, the most likely reasons are lack of power or a failed laser.

## **Laser gradually loses power**

This is normal; over time, the laser will gradually lose power until it finally dims out entirely. If this is happening, contact High End Systems Customer Service in one of the ways shown in “Contacting High End Systems” on page Intro-4.

## **Laser is out of position**

Align the laser as shown in the section titled “Technobeam Laser Aiming Device™” on page 6-19.

## **Emission Indicator LED OFF, Laser OFF**

The laser circuit board is not receiving power.

1. Unplug the fixture and remove the access door shown in Figure 5-3:

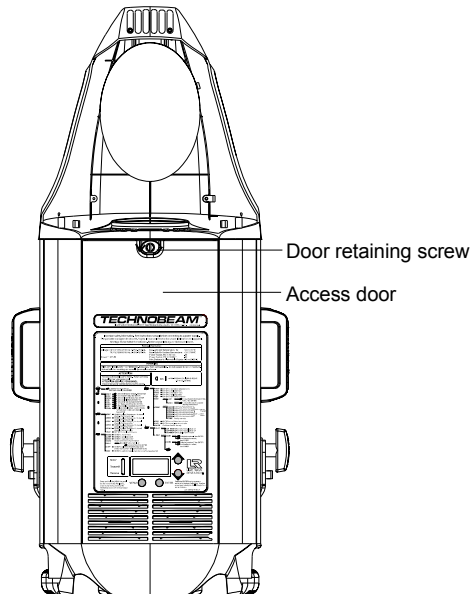

Figure 5-3. Removing the access door.



2. Check all wiring connections shown in Figure 5-4:

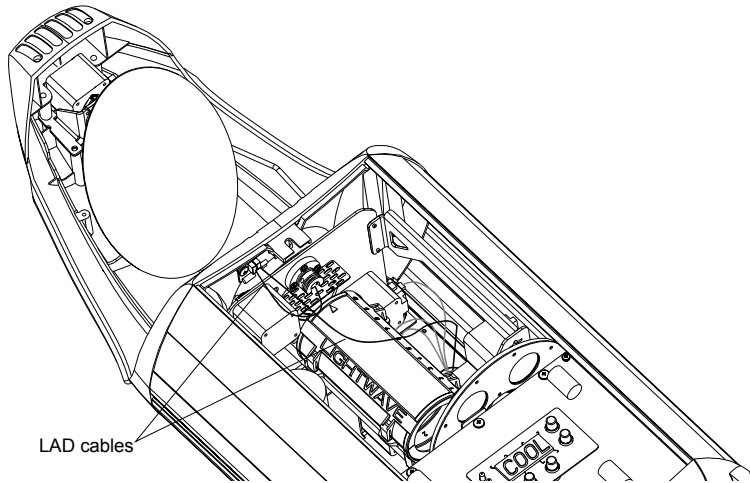

Figure 5-4. LAD wiring connections.

3. Check to make sure the cable labeled “LAD” is connected to the main circuit board (with the LED display).
4. Replace the access door, plug the fixture in and make sure you have enabled the laser as shown in the section titled “Controlling the Laser” on page 5-5.
5. If the Emission Indicator LED and laser are both still OFF, contact High End Systems Customer Service in one of the ways shown in “Contacting High End Systems” on page Intro-4.

## ***Emission Indicator LED ON, Laser OFF***

1. The laser aiming device assembly is not receiving power. Check the connection at the laser aiming device circuit board, shown in Figure 5-5.

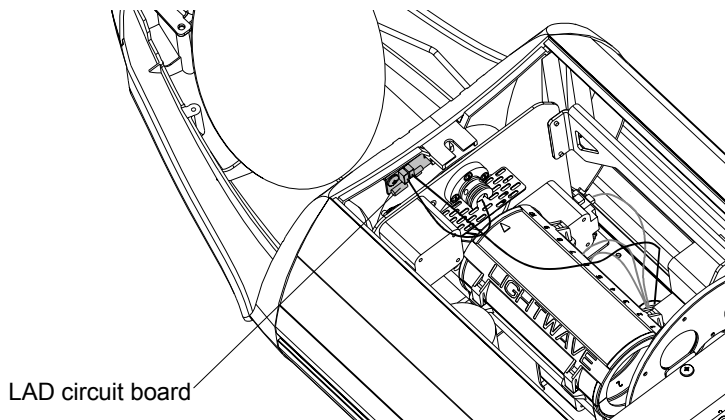

Figure 5-5. The laser aiming device circuit board.

2. If the cable connections are good, contact High End Systems Customer Service in one of the ways shown in “Contacting High End Systems” on page Intro-4.

## **Laser ON, Emission Indicator LED OFF**

The most likely reason is a faulty Emission Indicator LED. Contact High End Systems Customer Service as shown in “Contacting High End Systems” on page Intro-4.

## **Maintenance**

---

The only laser maintenance procedure is alignment, which is covered in the section titled “Technobeam Laser Aiming Device™” on page 6-19.

# Chapter 6

## Servicing Your Fixture

Precautions .....	6-2
Replacing Fuses .....	6-2
Replacing Wheel Components .....	6-4
Specifications .....	6-4
Reference Drawing .....	6-5
Replacing Dichroics in the Color Wheel .....	6-5
Replacing Lithos in the Rotating Litho Wheel .....	6-7
Removing a Rotating Litho or Rotating Effect .....	6-7
Removing a Static Litho .....	6-8
Cleaning the Litho .....	6-8
Litho Installation Instructions .....	6-9
Replacing a Static Litho .....	6-9
Replacing a Rotating Litho or Effect .....	6-10
Replacing a Custom Litho .....	6-11
Replacing the Lamp .....	6-11
Optimizing the Lamp .....	6-14
Resetting Lamp Hours .....	6-15
Cleaning the Internal Components .....	6-15
Opening the Fixture .....	6-16
Cleaning the Door Vents .....	6-16
Cleaning the Lenses and Mirrors .....	6-16
Technobeam Laser Aiming Device™ .....	6-19
Safety Precautions .....	6-19
Live Components .....	6-20
Alignment Procedure .....	6-21

# Precautions

---

This section lists precautions you must follow anytime you are servicing the fixture.

**WARNINGS** Before performing any service or maintenance, make note of the following:



**(1) Hot lamp may be an explosion hazard. Do not open for 5 minutes after switching off. Wear eye and hand protection when re-lamping.**

**(2) Equipment surfaces may reach temperatures up to 70° C (158° F). Allow 5 minutes for cooling before handling.**

**(3) Disconnect power before re-lamping or servicing.**



**(4) Replace fuses with the specified type and rating *only*.**

**(5) Never look directly at the lamp while lamp is on.**

**(6) The procedures in this chapter are intended to assist qualified service personnel because Technobeam fixtures are to be serviced by qualified service personnel *only*.**

## Replacing Fuses

---

This section explains how to replace any of the three fuses located on the fixture's circuit board. Make note of the warnings in the section titled "Precautions" on page 6-2.

Table 6-1. Replacement Fuses

Fuse	Amps	Volts	Fuse Type
F1	4.0 A	125 V	Fast Blow Only
F2	2.5 A	250 V	Fast Blow Only
F3	6.3A	250 V	Slow Blow Only

**Note** All fuses are 5 mm x 20 mm.

Table 6-2 describes the typical failure symptoms of each of the fuses:

*Table 6-2. Fuse Failure Symptoms*

Fuse	Protects	Symptoms of Failure
F1	Motor power	Motor LED is OFF when fixture is receiving power. Receive LED might be ON. Motors and gears will not move, lamp is OFF.
F2	Logic power	Fixture shuts down, LEDs might be ON.
F3	Main fuse	Fixture shuts down, LEDs are all OFF.

1. Unplug the fixture from the power supply.
2. Lay the fixture on its back and locate the door retaining screw, as shown in Figure 6-1:

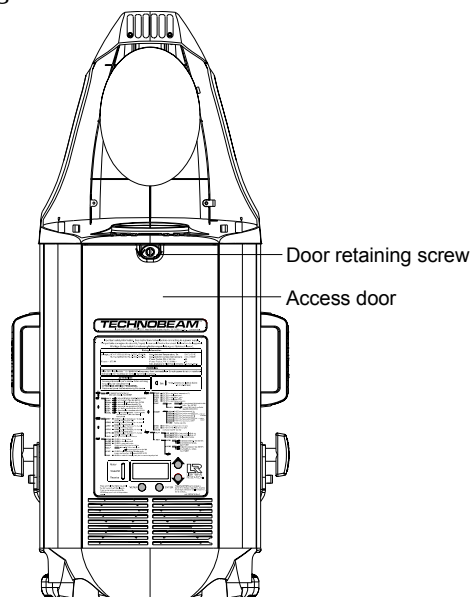

*Figure 6-1. Removing the door allows you to access the fixture's voltage selection switches and fuses, as well as wheels and optics.*

3. Note which fuse(s) needs to be replaced and make sure you replace it with a fuse of the same type and rating, as shown in Table 6-2.

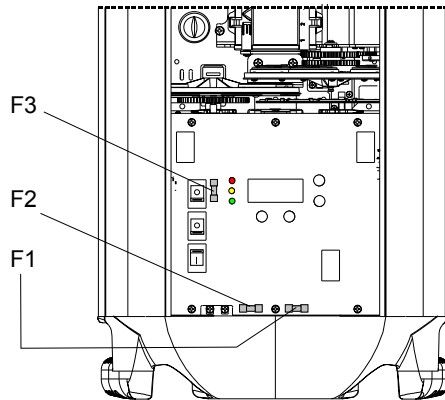

Figure 6-2. Locations of the three fuses on the circuit board.

4. Replace the access door and connect the fixture to a power supply.

## Replacing Wheel Components

This section explains how to remove and replace individual components in the wheels. Follow the precautions listed in the section titled “Precautions” on page 6-2.



**Always heed the following precautions when handling and using dichroics, lithos and effects:**

- **Avoid touching the coated side of the glass. Handle the edge or uncoated side of the glass when removing or installing lithos. If possible, wear cloth gloves when inserting and removing lithos from the litho wheel housing.**
- **If necessary, clean the lithos with a mild glass cleaner and a soft cloth.**

## Specifications

You can install any High End Systems-manufactured solid dichroic filters, effects, LithoPatterns lithos, ArtGlass, or Fusion Fire<sup>®</sup>—as long as they were manufactured for use with Technobeam, Technopro or Technoray and not another fixture.

You can also install dichroics, gobos, lithos or effects from other manufacturers as long as they adhere to the following specifications:

### Dichroics

- Diameter: 1.125" ± 0.010" (28.5 mm ± 0.25 mm)
- Thickness: 0.069" ± 0.010" (1.8 mm ± 0.25 mm)

## Lithos

- Diameter/image area: 0.996"/0.860"  $\pm$  0.005" (25 mm/22 mm  $\pm$  0.13 mm)
- Maximum thickness (rotating litho only): 0.105"  $\pm$  0.005" (2.7 mm  $\pm$  0.13 mm)
- Thickness (static litho only): 0.069"  $\pm$  0.010" (1.8 mm  $\pm$  0.25 mm)

## Rotating effects

- Diameter/image area: 1.43"/1.04"  $\pm$  0.010" (36 mm/26 mm  $\pm$  0.25 mm)
- Maximum thickness: 0.175"  $\pm$  0.010" (4.4 mm  $\pm$  0.25 mm)

## Reference Drawing

Figure 6-3 shows the location of each wheel in the Technobeam fixture.

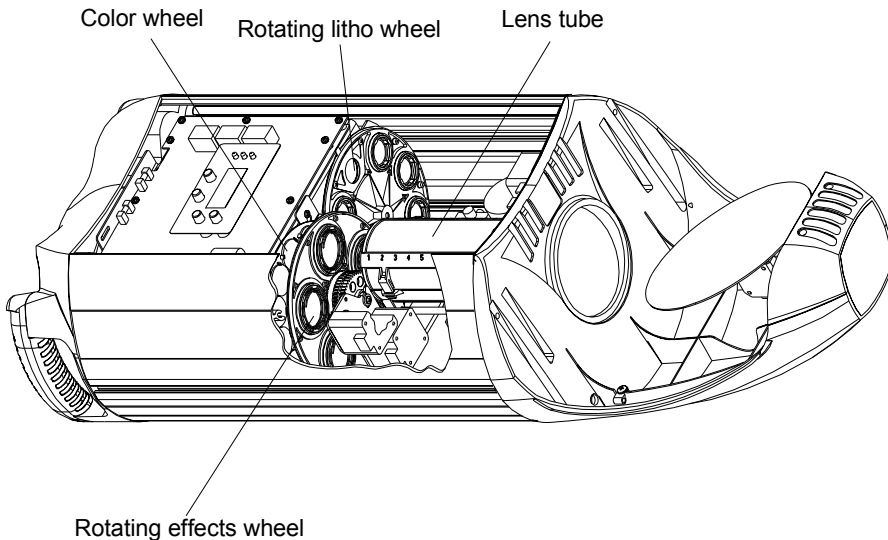

Figure 6-3. Location of the wheels in Technobeam.

## Replacing Dichroics in the Color Wheel

This section shows how to change individual dichroic filters in the color wheel. You can replace dichroics if they are damaged or broken, to change the order in their respective wheels, to clean them, or to add new ones. (See the section titled "Optional Accessories" on page 1-5 for ordering information.)

1. Manually turn the wheel so the dichroic you wish to replace is easy to access.

2. Push the dichroic you wish to replace toward the center of the wheel to free it from the two wheel tabs as shown in Figure 6-4.

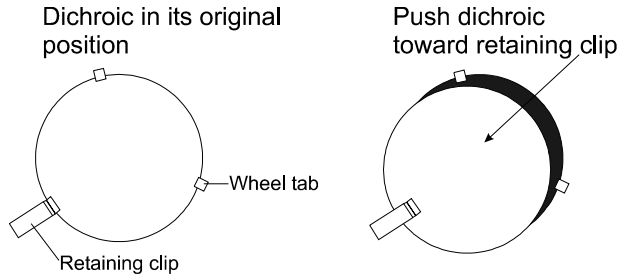

Figure 6-4. Push the dichroic toward the large retaining tab to free it from the wheel tabs.

3. Once the dichroic is free of the two wheel tabs, pull it out of the wheel. If you intend to reuse this dichroic, put it in a safe place where it will not get scratched.
4. Clean the dichroic, if necessary, with a mild glass cleaner (*containing no ammonia*) and a soft, lint-free cotton cloth.
5. Carefully install the replacement dichroic, oriented so the coated side is facing *toward the lamp* and the uncoated, glass side is facing toward the rotating litho wheel.

To determine which side is coated, place the tip of a pen against each side of the dichroic. Look at the dichroic and pen from a slight angle. On the coated side, the tip of the pen appears to “touch” its reflection. On the uncoated side, there appears to be a gap between the pen and its reflection (see Figure Figure 6-5).

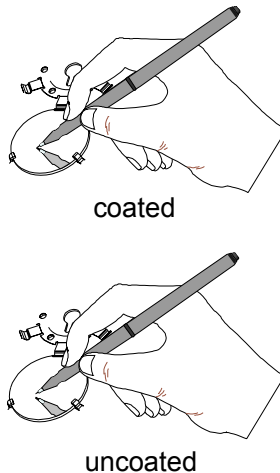

Figure 6-5. You can easily tell which side of a dichroic is coated by placing a pen or other object near the surface; on the coated side, the reflection from the object will appear to touch the object.



6. Install the new dichroic into its wheel by pushing it under the large retaining clip, then pull it up so it fits under the wheel tabs. Repeat the procedure for each dichroic you wish to replace.
7. Replace the access door shown in Figure 6-1 on page 6-3 unless there are other dichroics, lithos or effects you want to replace.

## **Replacing Lithos in the Rotating Litho Wheel**

This section explains how to replace either of the two lithos in each position on the Technobeam or Technoray rotating litho wheel: the *rotating litho* (facing the rotating effects wheel) and the *static litho* (directly behind the rotating litho).

You can replace lithos if they are damaged or broken, to change the order in their respective wheels, to clean them, or to add new ones. (See the section titled “Optional Accessories” on page 1-5 for ordering information.)

## **Removing a Rotating Litho or Rotating Effect**

1. Rotate the wheel until the desired litho is easy to access.
2. Make note of the plastic tabs built into the wheel, as shown in Figure 6-6.

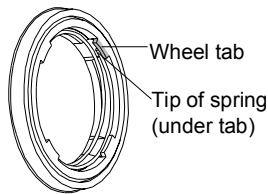

*Figure 6-6. The rotating litho wheel and rotating effects wheel have built-in plastic tabs that hold the spring in place.*

3. Locate the tip of the metal spring (which should be under one of the tabs). Carefully grasp the tip of the spring with your finger and push it from under the tab.
4. Rotate the spring as you remove it from the housing. Continue pressing the spring under each tab until the spring is completely free of the wheel.
5. Keep the wheel holder in place with one hand and grasp the spring with the other hand. Grasp the spring and carefully pull it free of the housing.

6. Reach in with your finger to remove the litho/effect and aperture ring (if any) from behind the spring.



Litho



Aperture  
ring

7. See one of the following:
  - a. Rotating litho wheel: “Litho Installation Instructions” on page 6-9.
  - b. Rotating effects wheel: “Replacing a Rotating Litho or Effect” on page 6-10.

## Removing a Static Litho

1. Rotate the wheel until the desired litho is easy to access.
2. Carefully spread the wheel apart and reach behind the wheel to remove the litho as shown Figure 6-7:

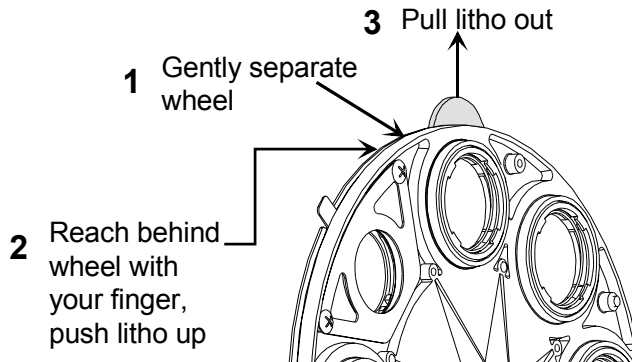

Figure 6-7. To replace a static litho in the rotating litho wheel, gently separate the wheel and reach behind the wheel to push the litho out.

## Cleaning the Litho

Clean the litho, if necessary, using a mild glass cleaner (*containing no ammonia*) and a soft, lint-free cotton cloth.

## Litho Installation Instructions

These instructions apply to installing either a rotating or a static litho in the rotating litho wheel. *Improper installation can result in damage to the litho.*

- **Custom multi-colored lithos in metal holder:** See “Replacing a Custom Litho” on page 6-11.
- **Etched pattern, no texture (LithoPatterns lithos):** the coated side of the litho must face *away from* the lamp; face the uncoated (glass) side toward the lamp.
- **Textured pattern (flat unglazed Art Glass, or Fusion Fire):** the textured side must face *away from* the lamp; face the non-textured (smooth) side *toward* the lamp.

## Replacing a Static Litho

1. Carefully handling the litho by its edges only, separate the wheel and drop the litho into the retaining slot and between the two retaining tabs as shown in Figure 6-8:

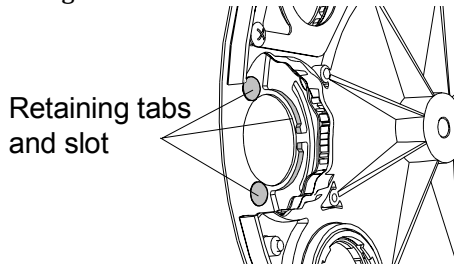

*Figure 6-8. Location of the retaining tabs and slot that secure the static litho in the rotating litho wheel.*

2. Insert a flat blade screwdriver or other thin object between the two parts of the rotating litho wheel to firmly seat the static litho in the retaining slots shown in Figure 6-8. *Avoid touching any part of the glass with your fingers.*
  - a. Examine the gap between the two parts of the rotating litho wheel; if the gap is uniform along the entire edge of the wheel, you are finished.
  - b. If the gap is not uniform, continue seating the static litho until the gap is uniform.

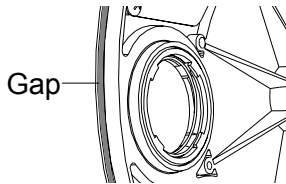

*Figure 6-9. The gap between the two halves of the rotating litho wheel must be uniform.*

## Replacing a Rotating Litho or Effect

1. Carefully handling the litho/effect by its edges only, orient it as shown when you replace it:
  - a. **Rotating litho wheel:** “Litho Installation Instructions” on page 6-9.
  - b. **Rotating effects wheel:** Orient the textured side of the effect *away from* the lamp. If the effect does not have a texture (e.g., the frost filter, orientation is not important).
2. If the litho/effect you are installing or replacing has an aperture ring, put the aperture ring on top of the litho. See Figure 6-10.

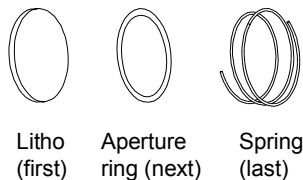

Figure 6-10. An aperture ring, if required, must be placed on top of the litho/effect and under the spring.

3. Carefully replace the spring, turning it as you compress it, until the spring is fully seated in the litho holder. *Make sure the spring fits completely under all wheel tabs and that the tip of the spring does not protrude from under the tabs.* See Figure 6-11:

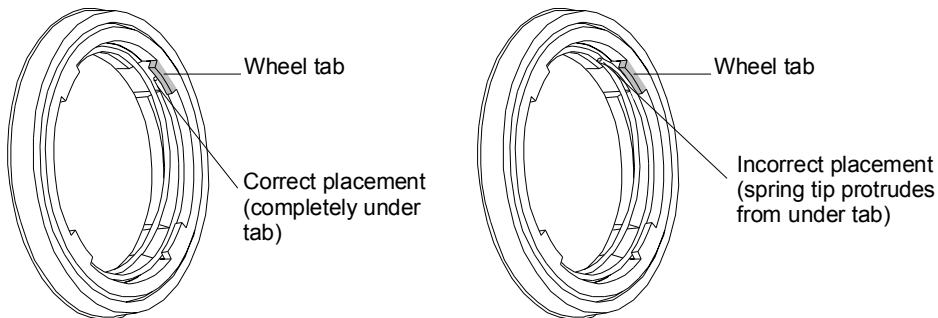

Figure 6-11. When you replace a rotating litho or rotating effect, make sure the tip of the spring is fully seated under the wheel tabs; it cannot protrude from under the tabs.

4. You are finished. Replace the access door shown in Figure 6-1 on page 6-3 unless there are other dichroics, lithos or effects you want to replace.

## Replacing a Custom Litho

If you received a custom, multi-colored litho in an aluminum holder, you must install it with the litho facing toward the lamp (i.e., the flat side of the holder against the spring), as shown in Figure 6-12.

*Improper installation can damage the litho!*

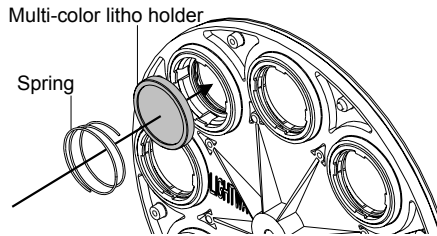
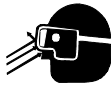

Figure 6-12. Replacing a custom multi-colored litho in the metal holder.

## Replacing the Lamp

You will need:



- 250 watt, GY9.5 base, M series metal halide lamp only\*
- Eye protection
- Protective gloves

**\*Note**

Use only the MSD250-2 lamp in your fixture, not the MSD 250. Technobeam fixtures are optimized for the MSD 250-2 lamp and will give reduced performance with other lamps.

- WARNINGS**
- (1) This equipment is designed for use with an M series, GY9.5 base, 250 watt (such as the MSD 250-2) lamp only. Use of any other type lamp may be hazardous and may void the warranty.**
  - (2) Change the lamp if it becomes damaged or thermally deformed.**
  - (3) Change shields, lenses or ultraviolet screens if they have become visibly damaged to such an extent that their effectiveness is impaired, for example, by cracks or deep scratches.**
  - (4) Do not operate this equipment without complete lamp enclosure in place or if shields, lenses or ultraviolet screens are damaged.**



**(5) Hot lamp may be an explosion hazard. Do not open for 5 minutes after switching off. Wear eye and hand protection when re-lamping.**

**(6) Never look directly at the lamp while lamp is on.**

**(7) Disconnect power before re-lamping or servicing.**

1. Unplug the fixture from the power source.
2. Fully back out the two lamp assembly screws shown in Figure 6-13.

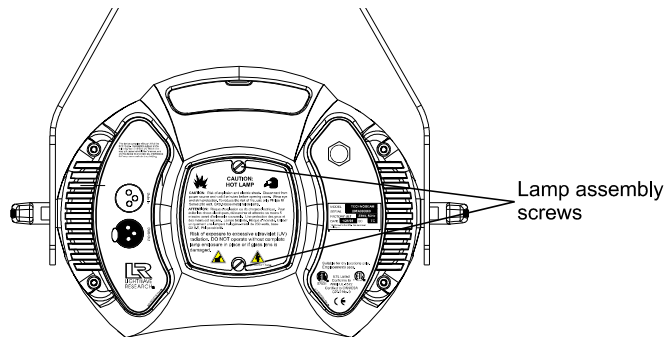

*Figure 6-13. Loosening the lamp assembly screws gives you access to the fixture lamp.*

3. *Put on your eye and hand protection.* Pull the lamp assembly straight out of the back of the fixture as shown in Figure 6-14.

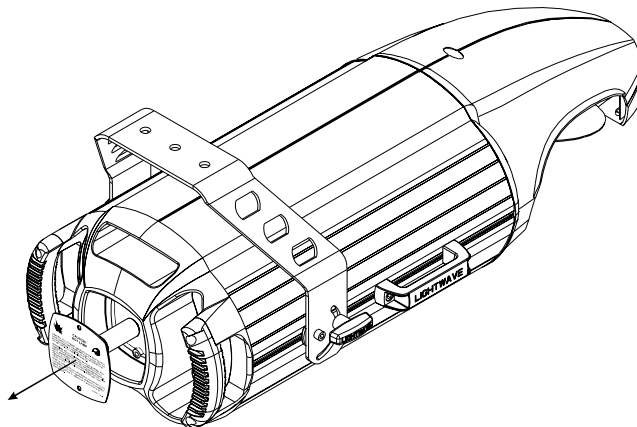

*Figure 6-14. Removing the lamp assembly from the fixture.*

4. If you are replacing a lamp, grasp the lamp's ceramic base and pull the old lamp straight up and out of the assembly when the assembly is free of the fixture, as shown in Figure 6-15:

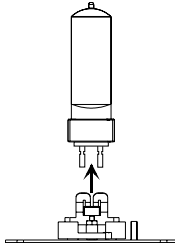

Figure 6-15. Pull straight up on the lamp, grasping its ceramic base, to remove it from the assembly.

5. Take the new or replacement lamp out of its container. Break the seal on the inner plastic container and remove the lamp.
6. Hold onto the ceramic lamp base and gently press the two lamp base pins into the brass lamp socket as shown in Figure 6-16. *Do not force the lamp into the socket; doing so could break the lamp.*

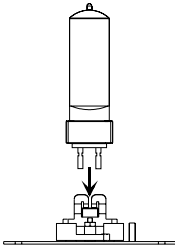

Figure 6-16. Hold the lamp by its ceramic base and gently press the two base pins into the socket.



### Caution

**Avoid touching any part of your skin to the lamp's quartz envelope. Oil and residue from your fingers can create a "hot spot" on the lamp, causing premature lamp aging.**

7. Before you insert the lamp assembly back into the fixture, clean the lamp with the alcohol wipe shipped with the lamp. Otherwise, fingerprints and other contaminants can shorten lamp life.
8. Carefully guide the lamp assembly straight back into the fixture. Make sure the lamp plate is oriented correctly, as shown in Figure 6-17; otherwise, the lamp power wires could wrap around the lamp, resulting in damage to the fixture and the lamp.

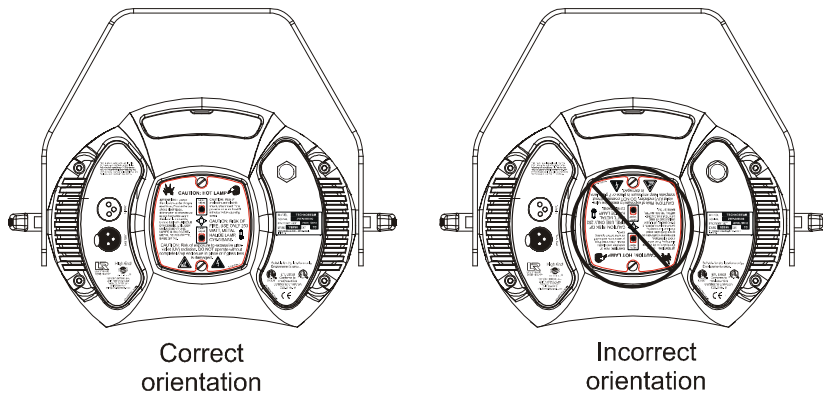

*Figure 6-17. You can look at the lamp label text to make sure the lamp plate is oriented correctly; incorrect orientation can result in damage to the fixture and the lamp.*

9. As you insert the lamp assembly, be careful not to crimp or trap the lamp wires and make sure the lamp is inserted into the reflector.
10. Firmly tighten the two lamp assembly screws to secure the assembly to the fixture.

## **Optimizing the Lamp**

You should optimize the lamp after you replace the lamp, or if you notice a “hot spot” of brightness anywhere other than the center of the light beam.

The optimization procedure below describes how to optimize the lamp using the fixture’s onboard menu system. However, you can access the same options using your DMX controller.

1. Orient the fixture so that the beam will project onto a flat, white surface at least 10 feet (3 m) away.
2. Turn the lamp on (see “Turning the Lamp On or Off (LAMP)” on page 3-20).
3. If necessary, set any lithos, colors, or effects values to “0” to achieve an open, white beam.
4. Make sure that the light beam is round and not oval. If necessary, adjust the pan and tilt construct values until the beam is round (see “Positioning the Mirror” on page 4-6).
5. Adjust the focus until the edge of the light beam is sharp (see “Refocusing the Fixture” on page 4-7).



6. Locate the two lamp optimization (adjust) screws (see Figure 6-18).

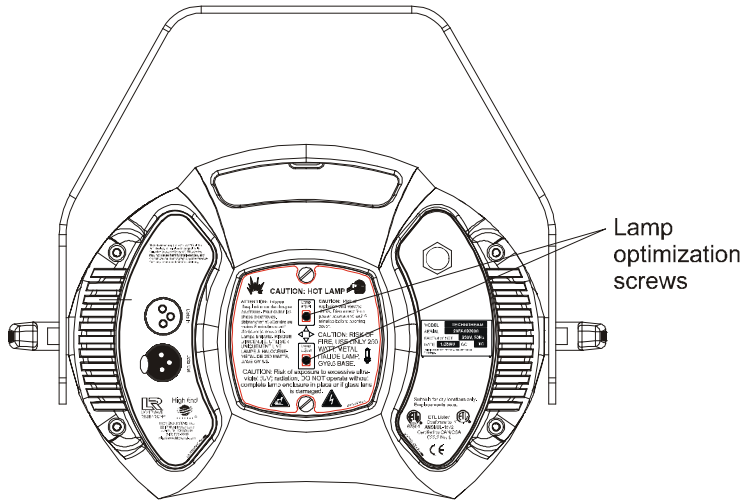

Figure 6-18. Lamp optimization screws.

7. Loosen the two lamp optimization screws.
8. Look at the wall where the beam is projected and use the two optimization screws to adjust the lamp's position within the fixture.
9. When the beam is at its maximum brightness and the light level is even across the beam (or the "hot spot" of brightness is at the center of the beam), retighten the two optimization screws to secure the lamp in its new position.

## Resetting Lamp Hours

After changing a lamp, you should reset the number of lamp hours to zero by selecting **L/RS** from the Info menu. See the menu system help card inside the back cover of this manual, or consult Chapter 3 if you need additional help using the menu system.

## Cleaning the Internal Components

Before continuing, read the cautions and warnings in the section titled "Precautions" on page 6-2.

**You will need:**

- a soft, lint-free cotton cloth
- mild glass cleaning solution
- warm soapy water

## Opening the Fixture

Unplug the fixture from the power outlet and allow it to cool for at least 5 minutes if it has been running recently. Remove the access door shown in Figure 6-19:

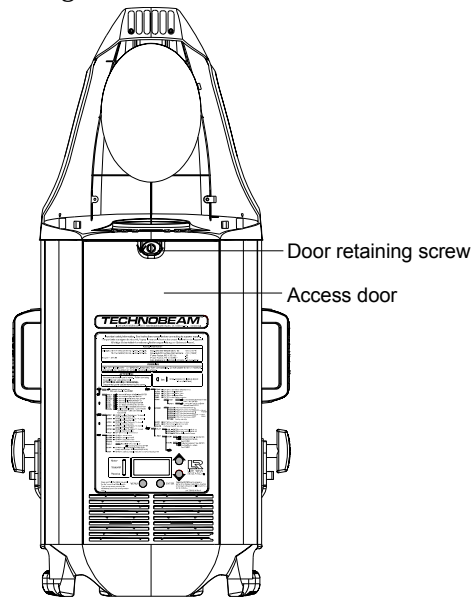

Figure 6-19. Opening the fixture's access door.

## Cleaning the Door Vents

Once the door is removed, use a soft, lint-free cotton cloth and warm soapy water if necessary to clean dust and dirt from the inside and outside of the vents shown in Figure 6-19.

## Cleaning the Lenses and Mirrors

1. If you need to move the lens tube so you can access the anti-reflective glass, reach under the lens tube and turn the focus drive screw (see Figure 6-20).
2. Clean both sides of the anti-reflective glass (shown in Figure 6-20) with a soft, lint-free cotton cloth and mild glass cleaning solution.

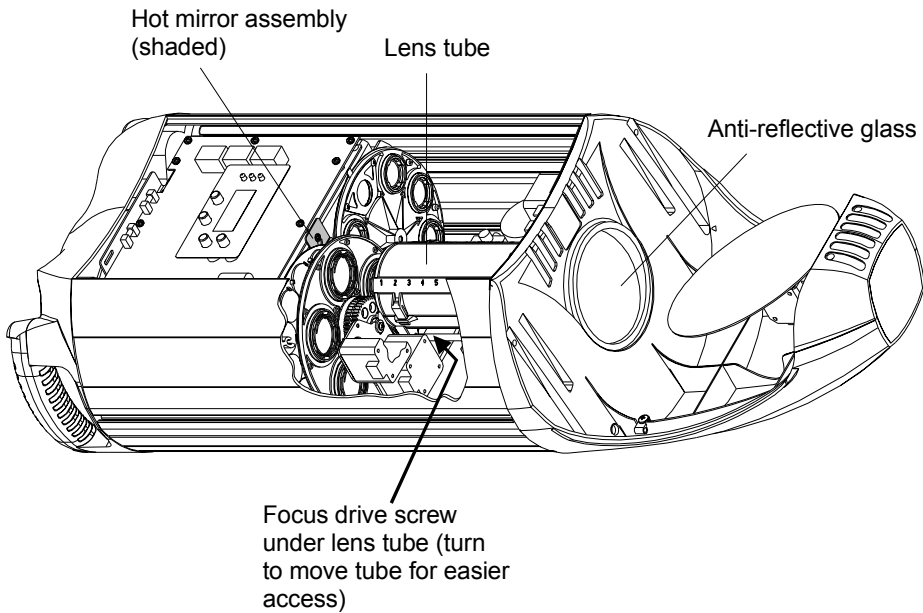

Figure 6-20. Location of the anti-reflective glass, lenses and hot mirror.

3. If the black dim flags (located between the lens tube and the anti-reflective glass) are closed, carefully use your fingers to open them to clean the inside of the glass.
4. Locate the lens tube as shown in Figure 6-21:

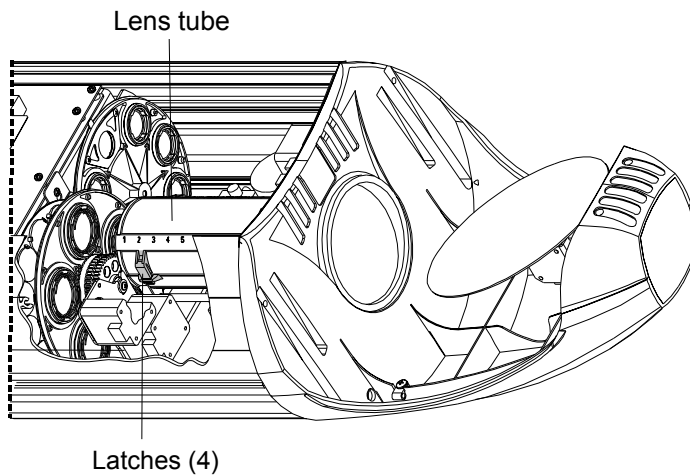
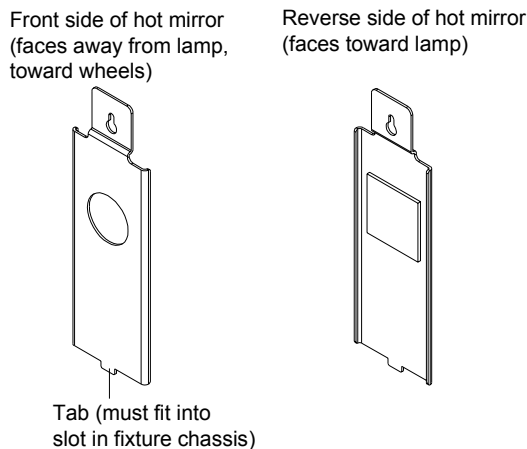

Figure 6-21. The lens tube contains the zoom lenses.

5. Carefully lift the cover from the lens tube. It has two latches on each side that secure it in place.

6. Write down the position of each of the lenses in the lens tube. (Each position is numbered both on the lens tube cover and on the inside of the lens tube.)
7. Handle each lens carefully by its edges only. Use a soft, lint-free cloth to clean the lenses. If necessary to remove built-up dirt and dust, use a mild glass cleaner (*containing no ammonia*).
8. Replace the lenses in the lens tube in the same positions as you removed them. Refer to Table 1-2 on page 1-14 or Table 1-3 on page 1-14 for reference.
9. Replace the cover on the lens tube. Make sure all four latches are fastened securely.
10. Use a Phillips screwdriver to loosen (but do not remove) the screw on the hot mirror tab, shown in Figure 6-20 on page 6-17.
11. Carefully remove the hot mirror assembly. Inspect the hot mirror (shown in Figure 6-22) for cracks, deep scratches or other damage. If you notice significant damage, High End Systems Customer Service in one of the ways shown in the section titled "Contacting High End Systems" on page Intro-4.



*Figure 6-22. Clean both sides of the hot mirror glass.*

12. Clean both sides of the hot mirror with a soft, lint-free cotton cloth.
13. Orient the hot mirror as shown in Figure 6-22.
14. When you replace the hot mirror assembly, make sure the tab shown in Figure 6-22 fits into a slot on the fixture chassis. When the tab is properly seated, you will be able to push the hot mirror down until the small end of the keyhole-shaped slot touches the Phillips screw.
15. *Technobeam only:* Clean the elliptical mirror on the mirror head with a cloth soaked in warm, soapy water.
16. Replace the access door shown in Figure 6-19 on page 6-16.

# Technobeam Laser Aiming Device™



You might need to realign the laser periodically in order to maintain its optimal position—no more than 2" (5 cm) directly above the center point of the light beam. If you align the laser in this way, the path of the laser is parallel to the path of the light and will stay 2" (5 cm) above the center point of the beam at any throw distance or mirror position.

You align the laser using the three mounting/alignment screws shown in Figure 6-27 on page 6-25.

However, the decision of whether or not to align the laser is entirely up to you. If the laser strays from its optimal position, but it gives you enough accuracy for your needs, you do not *have to* align it.

Figure 6-23 shows the ideal position of the laser from the center of a perfectly round light beam:

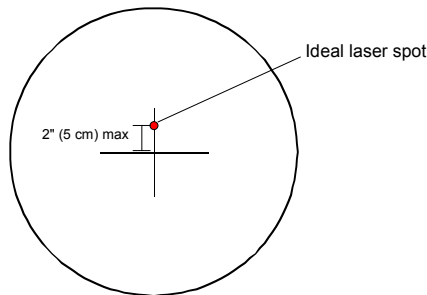

Figure 6-23. The ideal position of the laser is no more than 2" (5 cm) directly above the center of a perfectly round light beam.

## Safety Precautions

In addition to observing all of the cautions in the section titled "Precautions" on page 6-2, you must observe the following cautions whenever using or servicing the Laser Aiming Device (LAD):

1. CAUTION: Use of controls or adjustments or performance of procedures other than those specified herein may result in hazardous radiation exposure.
2. Using the Laser Aiming Device with any fixture other than Technobeam may result in damage to both the laser and the fixture as well as exposure to laser radiation.
3. Precautions should be taken to ensure that the laser beam is not unintentionally directed at mirror-like (specular) surfaces (most importantly, at flat mirror-like surfaces).

4. Only qualified and trained employees approved by a laser safety officer should be assigned to install, adjust and operate the laser equipment.
5. When not in use, the laser (fixture) should be stored in a location where unauthorized personnel cannot gain access.
6. Do not stare directly into the beam and do not view the beam with optical instruments.
7. The laser path should be located well above or below eye level.

The section titled “Safety Precautions” on page 5-2 has a complete listing of safety precautions for using the Laser Aiming Device.

## Live Components

You will be accessing live components and adjusting the laser in the next section. Take special care to avoid contacting high-voltage live components, located in the area of the main circuit board, shown in Figure 6-24:

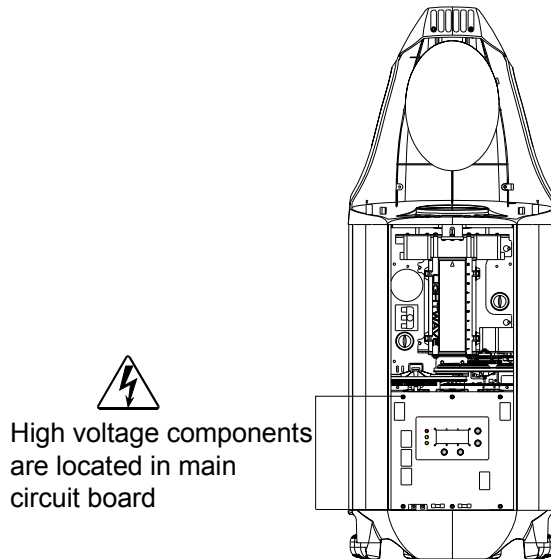

Figure 6-24. High-voltage component location.

When you activate the laser, observe the following precaution:



### Caution

**Do not stare into the beam or view it directly with optical instruments. Avoid accidental exposure to laser radiation.**

# Alignment Procedure

The alignment procedure that follows takes advantage of Technobeam's built-in program storage capability to turn the laser ON.

1. Follow the instructions in Chapter 1 to select a voltage setting and install a power cord cap, if you have not already done so.
2. Physically orient the fixture as shown in Figure 6-25 (the farther away the wall is, the more accurate your positioning will be):

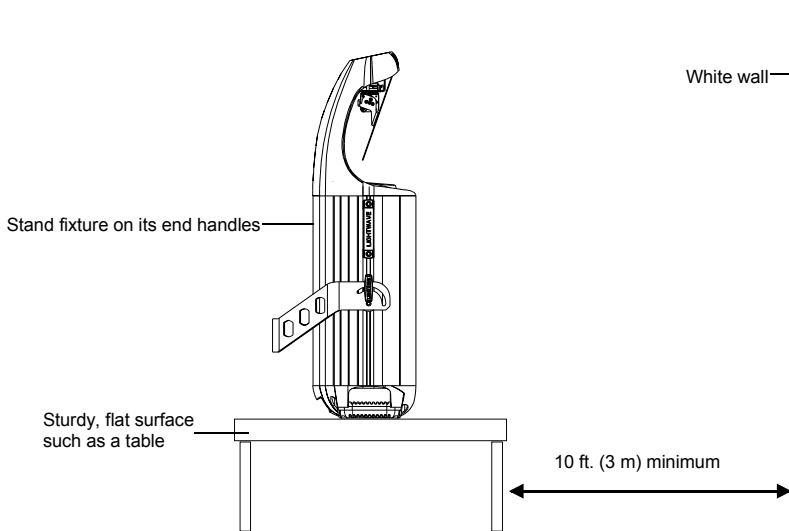

Figure 6-25. Orient the fixture directly facing a wall no less than 10 ft. (3 m) away.

3. Connect the fixture to an appropriately-rated power outlet. You will hear sounds as wheels and motors seek their home positions; *this is normal.*

Addr

4. When the fixture has finished homing, press and hold the <Menu> key until the LED display reads **ADDR**.

The next steps show how to turn the lamp ON.

TEST

5. Use the <Up> and <Down> arrow keys to navigate to the **TEST** menu.

LAMP

6. Press <Enter>, then use the <Up> and <Down> arrow keys to navigate to the **LAMP** option.
7. Press <Enter>, then use the <Up> and <Down> arrow keys to select a value of **ON**.
8. Press <Enter>; the lamp should now be on (although you will not be able to tell if the dim flags are closed).

The next steps show you how to access the fixture's built-in programming menu to begin aligning the laser.

- PRST** 9. Keep pressing the <Menu> key until the **ADDR** menu is displayed.
10. Use the <Up> and <Down> arrow keys to navigate to the **PRST** menu.
- EDIT** 11. Press <Enter>, then use the <Up> and <Down> arrow keys to navigate to the **EDIT** menu option. The EDIT option allows you to create or edit up to eight scenes which are stored in the fixture's onboard memory.
- SCN2** 12. Press <Enter>. Use the <Up> and <Down> arrow keys to select the scene number of an unprogrammed scene. For example, selecting **SCN2** means you will edit scene number 2.
13. Press <Enter> to begin editing the scene you selected.
14. If you selected an unprogrammed scene, skip to Step 17 now; otherwise, continue with the next step. If the fixture started making noises of gears and wheels moving as soon as you selected the scene, and the noises continue for more than a brief period of time, you selected a programmed scene.

The next two steps show how to unprogram a scene; you need to unprogram the scene in order to make sure all constructs are set to default values. This is necessary only if all eight scenes are already programmed.

- ZERO** 15. Use the <Up> and <Down> arrow keys to navigate to the **ZERO** option.
16. Press <Enter>; you will be required to confirm the action by pressing <Enter> again.

Step 17 through Step 22 shows how to open the shutter and set the dim construct to full bright. You can skip these steps if you can clearly see the light projected onto the wall.

17. Use the <Up> and <Down> arrow keys to navigate to the **SHUT** option.
18. Press <Enter>, then use the <Up> and <Down> arrow keys to select a value of **OPEN**.
19. Press <Enter> to accept your selection.
20. Use the <Up> and <Down> arrow keys to navigate to the **DIM** option.
21. Press <Enter>, then use the <Up> and <Down> arrow keys to select a value of **D255** (full bright).
22. Press <Enter> to accept your selection.

You should now see the white, round shape of the beam projected onto the wall or white surface.

- If the beam is round (not oval) in shape, continue with Step 31.
- If the beam is not round in shape, see the next step.



23. Make sure the fixture is oriented directly at the wall, not at an angle. If the fixture is at an angle to the wall, it might be impossible to align the laser properly.
24. Use the <Up> and <Down> arrow keys to navigate to the **TILT** option.
25. Press <Enter>, then use the <Up> and <Down> arrow keys to adjust the mirror position until the beam is round.
26. Press <Enter> to accept your selection for TILT.
27. If the beam needs further adjustment, use the <Up> and <Down> arrow keys to navigate to the **PAN** option.
28. Press <Enter>, then use the <Up> and <Down> arrow keys to adjust the mirror position.
29. Press <Enter> to accept your selection for PAN.
30. Continue adjusting the mirror using PAN and TILT until the beam is as round as possible.  
  
If you cannot see the beam at all, the lamp might be off. Select **LAMP** from the Test menu and make sure a value of **ON** is displayed; see Step 5 through Step 8. (If the lamp still does not come on, wait a few minutes and try again.)
31. Use the <Up> and <Down> arrow keys to navigate to the **FCUS** option.
32. Press <Enter>, then use the <Up> and <Down> arrow keys to focus on the edge of the beam until it is sharp.
33. Continue moving the fixture and focusing on the edge of the beam until the beam is as round as possible, and sharply in focus.
34. When you have focused the beam, press <Enter>.

35. Find the approximate center of the beam using either a tape measure, ruler or a piece of string, as shown in Figure 6-26.

- 1 Extend the tape measure or string down at the widest part of the beam

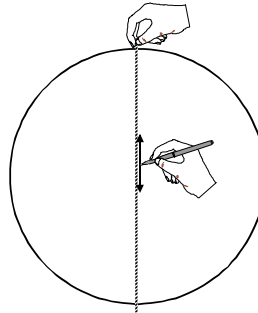
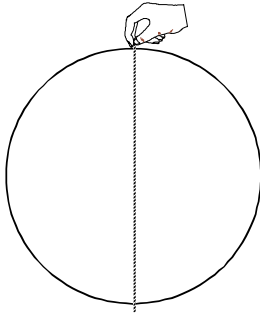

- 2 Lightly mark on the wall along the string

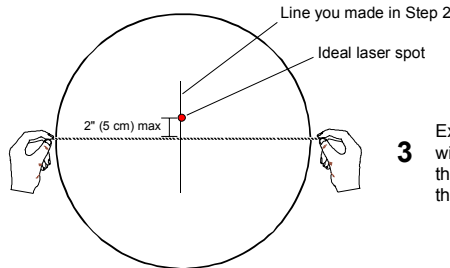

- 3 Extend the string across the beam's widest point. Laser should be no more than 2" (5 cm) above the string, along the center line.

Figure 6-26. Locating the center point of the projected light beam. The laser should be no more than 2" (5 cm) above the center.

ADDR

36. Once you have marked the center point of the beam, keep pressing the <Menu> key until the **ADDR** option is displayed.

TEST

37. Use the <Up> and <Down> arrow keys to navigate to the **TEST** menu.

LAMP

38. Press <Enter>, then use the <Up> and <Down> arrow keys to navigate to the **LAMP** option.

39. Press <Enter>, then select a value of **OFF**.

40. Press <Enter>. The lamp now shuts off.

41. Keep pressing the <Menu> key until the **ADDR** option is displayed.

42. Use the <Up> and <Down> arrow keys to navigate to the **PRST** menu.

43. Use the <Up> and <Down> arrow keys to navigate to the **EDIT** option.

44. Press <Enter>, then use <Up> and <Down> arrow keys to navigate to the **SCN2** option (this selects scene number 2; select the same scene you selected in Step 12).



**Caution**

**Do not stare into the laser beam or view it directly with optical instruments.**

MACR

45. Press <Enter>, then use the <Up> and <Down> arrow keys to navigate to the **MACR** option.

LRON

46. Press <Enter>, then use the <Up> and <Down> arrow keys to select **LRON** (laser on continuously).

47. Press <Enter> to accept your selection.

48. Look at the wall where the beam is projected onto to determine if the laser is on.

49. If the laser does not come on, see the section titled “Troubleshooting” on page 5-6; otherwise, continue with the next step.

50. Figure 6-27 shows the 3 mounting/alignment screws located on the laser aiming device assembly. See the instructions that follow the drawing.

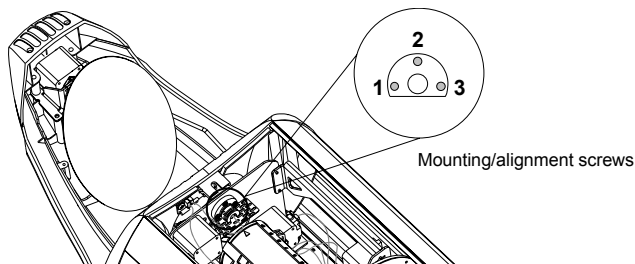

Figure 6-27. The laser aiming device assembly has three screws that can be used to adjust the position of the laser.

Alignment screws 1 and 3 (shown in Figure 6-27) move the laser horizontally, and screw 2 moves the laser vertically. Use the three alignment screws to adjust the position of the laser so that it is no more than 2” (5 cm) directly above the center point of the beam, shown in Figure 6-23 on page 6-19.

51. After you tighten/loosen each screw, release pressure from the screwdriver before looking at the laser position on the wall; having pressure on the screw can change the laser’s position. *Do not force the screws or fully tighten them because the ends of the screws might interfere with the dim flags.*

**Hint** If you have difficulty aligning the laser or turning the screws, loosen all three screws and start over.

52. Continue repeating the procedure until the laser is aligned. (If you cannot get your laser exactly at position shown in Figure 6-23 on page 6-19, but it is still at a position you think will give you enough accuracy for your needs, you are finished.)

53. When you’re finished, replace the access door shown in Figure 6-19 on page 6-16.



# Appendix A

# DMX Protocols

## General Information

---

The information in this section applies to all of the protocols listed in this Appendix (except where noted).

### Rounding Conventions

The values displayed in the columns “Value (dec.)”, “Value (%)” and “Value (hex)” in the following tables may vary slightly depending on your controller’s rounding convention.

### 16-Bit Control

The full protocol for Technobeam gives you 16-bit control over the positioning of the mirror and the angular position of rotating lithos. However, you always have smooth, 16-bit control over *movement*, even if you choose the reduced protocol—which gives you 8-bit control over mirror and litho positioning.

The full protocols give you two channels of position control: one channel sets the *most significant* 8 bits (*coarse adjustment*), while the second channel sets the *least significant* 8 bits (*fine adjustment*) of a 16-bit value. The high order bit gives you 256 times the number of litho position stops (65,536 for 16-bit compared to 256 for 8-bit).

### Macros

Technobeam full protocol offers 28 selectable macros to simplify programming. A *macro* is a set of preconfigured constructs you can use with any other combination of constructs you want, except Laser Aiming Device constructs. Because the Technobeam Laser Aiming Device shares the same DMX channel, you cannot use both macros and the Laser Aiming Device at the same time.

## ***MSpeed vs. Fast Changes***

There are two different ways you can choose to move the color and litho wheels: fast changes or MSpeed changes.

A *fast* change means the color or litho movement is completed in the shortest amount of time after the wheel starts moving.

An *MSpeed* (motor/mirror speed) change occurs smoothly over the entire MSpeed time value. For example, if you choose a numerical DMX value of 202 for an MSpeed color change from position 2 to position 4, that means the color wheel changes gradually to position 4 over 11.41 seconds. (Most controllers also allow you to program advanced features, like crossfade or delay time. Make sure your MSpeed value is at least as long as the crossfade or delay time; otherwise, the color or litho change will not complete before the next page or scene starts.)

MSpeed time values are shown in Table A-3 on page A-13.

## ***Ramp Open, Snap Shut***

The Shutter construct includes parameters named “Ramp open, snap shut” and “Snap open, ramp shut”. A *snap* is an instant shutter movement (opening or closing); the snap time never varies. What you can vary is the timing of the *ramp*, which is a gradual shutter movement. A lower value always means a longer ramp, and a higher value always means a shorter ramp.

## ***Forward and Reverse Spins***

A *forward* spin on all wheels and positions means the wheel or position spins clockwise as you’re looking at the projected image. A *reverse* spin means the wheel or position spins counter-clockwise.

# Technobeam<sup>®</sup> Protocol

Table A-1 gives the DMX channel assignments for the Technobeam full 18-channel protocol and reduced 14-channel protocol. The column “Ch. (F)” lists channel assignments for the full protocol and the column “Ch. (R)” lists channel assignments for the reduced protocol.

Table A-1. Technobeam DMX Protocol

Ch. (F)	Ch. (R)	Construct	Parameter	Value (dec.)	Value (%)	Value (hex)
1	1	Pan (mirror) position	Coarse adjustment	0 - 255	0 - 100	00h - FFh
2	n/a	Pan (mirror) position	Fine adjustment	0 - 255	0 - 100	00h - FFh
3	2	Tilt (mirror) position	Coarse adjustment	0 - 255	0 - 100	00h - FFh
4	n/a	Tilt (mirror) position	Fine adjustment	0 - 255	0 - 100	00h - FFh
5	3	<b>Color wheel functions</b>  Fast color change (at beginning of wheel movement)  Select the function with this channel. Then use ch. 6 (F) or 4 (R) to set the position or spin speed.	Indexed (wheel snaps to center of aperture)	0 - 15	0 - 5	00h - 0Fh
			Forward spin	16 - 31	6 - 12	10h - 1Fh
			Reverse spin	32 - 47	13 - 18	20h - 2Fh
			Continuous	48 - 63	19 - 24	30h - 3Fh
			Slow scan	64 - 79	25 - 30	40h - 4Fh
			Fast scan	80 - 95	31 - 37	50h - 5Fh
			Random	96 - 111	38 - 43	60h - 6Fh
		Blink (same as index, except shutter closes between apertures)	112 - 127	44 - 49	70h - 7Fh	
		Color changes set by MSpeed (use ch. 16 (F) or 13 (R) to set MSpeed time).  Select the parameter with this channel. Then use ch. 6 (F) or 4 (R) to set the position or spin speed.	Indexed (wheel snaps to center of aperture)	128 - 143	50 - 56	80h - 8Fh
			Forward spin	144 - 159	57 - 62	90h - 9Fh
			Reverse spin	160 - 175	63 - 68	A0h - AFh
			Continuous	176 - 191	69 - 74	B0h - BFh
			Slow scan	192 - 207	75 - 81	C0h - CFh
			Fast scan	208 - 223	82 - 87	D0h - DFh
Random	224 - 239		88 - 93	E0h - EFh		
Blink (same as index, except shutter closes between apertures)	240 - 255	94 - 100	F0h - FFh			
6	4	<b>Color wheel position and functions</b>  Position (aperture) selection for blink or index mode (use with ch. 5 (F) or 3 (R))	Position 1 (open)	0 - 23 248 - 255	0 - 9 97 - 100	00h - 17h F8h - FFh
			Position 2	24 - 31	9 - 12	18h - 1Fh
			Position 3	32 - 39	13 - 15	20h - 27h

Table A-1. Technobeam DMX Protocol

Ch. (F)	Ch. (R)	Construct	Parameter	Value (dec.)	Value (%)	Value (hex)
			Position 4	40 - 47	16 - 18	28h - 2Fh
			Position 5	48 - 55	19 - 21	30h - 37h
			Position 6	56 - 63	22 - 24	38h - 3Fh
			Position 7	64 - 71	25 - 27	40h - 47h
			Position 8	72 - 79	28 - 30	48h - 4Fh
			Position 9	80 - 87	31 - 34	50h - 57h
			Position 10	88 - 95	35 - 37	58h - 5Fh
			Position 11	96 - 103	38 - 40	60h - 67h
			Position 12	104 - 111	41 - 43	68h - 6Fh
			Position 13	112 - 127	44 - 49	70h - 7Fh
			Half color 1 and 2	128 - 143	50 - 56	80h - 8Fh
			Half color 2 and 3	144 - 151	57 - 59	90h - 97h
			Half color 3 and 4	152 - 159	60 - 62	98h - 9Fh
			Half color 4 and 5	160 - 167	63 - 65	A0h - A7h
			Half color 5 and 6	168 - 175	66 - 68	A8h - AFh
			Half color 6 and 7	176 - 183	69 - 71	B0h - B7h
			Half color 7 and 8	184 - 191	72 - 74	B8h - BFh
			Half color 8 and 9	192 - 199	75 - 78	C0h - C7h
			Half color 9 and 10	200 - 207	79 - 81	C8h - CFh
			Half color 10 and 11	208 - 215	82 - 84	D0h - D7h
			Half color 11 and 12	216 - 223	85 - 87	D8h - DFh
			Half color 12 and 13	224 - 231	88 - 90	E0h - E7h
			Half color 13 and 1	232 - 247	91 - 96	E8h - F7h
		Color wheel continuous forward/ reverse spin (use with ch. 5 (F) or 3 (R))	No spin	0 - 3	0 - 1	00h - 03h
			Slowest spin to fastest spin	4 - 255	2 - 100	04h - FFh
		Color wheel continuous variation (wheel position is 360 * (channel dec. value / 255)  Use with ch. 5 (F) or 3 (R)	Centered on position 1 (open)	0 255	0 100	00h FFh
			Centered on position 2	19	7	13h
			Centered on position 3	39	15	27h
			Centered on position 4	58	23	3Ah
			Centered on position 5	78	31	4Eh
			Centered on position 6	98	38	62h
			Centered on position 7	117	46	75h
			Centered on position 8	137	54	89h
			Centered on position 9	156	61	9Ch



Table A-1. Technobeam DMX Protocol

Ch. (F)	Ch. (R)	Construct	Parameter	Value (dec.)	Value (%)	Value (hex)
			Centered on position 10	176	69	B0h
			Centered on position 11	196	77	C4h
			Centered on position 12	215	84	D7h
			Centered on position 13	235	92	EBh
7	5	<b>Litho wheel functions</b>  Fast litho changes (at beginning of wheel movement)  Select the function with this channel. Then use chs. 8, 9 & 10 (F) or chs. 6 & 7 (R) to set other options.  Random and scan pause time set by chs. 9 & 10 (F) or ch. 7 (R)	Indexed (wheel snaps to center of aperture)	0 - 15	0 - 5	00h - 0Fh
			Forward spin	16 - 31	6 - 12	10h - 1Fh
			Reverse spin	32 - 47	13 - 18	20h - 2Fh
			Scan	48 - 63	19 - 24	30h - 3Fh
			Blink (same as index, except shutter closes between apertures)	64 - 79	25 - 30	40h - 4Fh
			Random	80 - 95	31 - 37	50h - 5Fh
			Reserved	96 - 111	38 - 43	60h - 6Fh
		Wheel spin	112 - 127	44 - 49	70h - 7Fh	
		Litho changes set by MSpeed (use ch. 16 (F) or 13 (R) to set MSpeed time)  Select the parameter with this channel. Then use chs. 8, 9 & 10 (F) or chs. 6 & 7 (R) to set other options.  Random and scan pause time set by ch. 9 (F) or ch. 7 (R)	Indexed (wheel snaps to center of aperture)	128 - 143	50 - 56	80h - 8Fh
			Forward spin	144 - 159	57 - 62	90h - 9Fh
			Reverse spin	160 - 175	63 - 68	A0h - AFh
			Scan	176 - 191	69 - 74	B0h - BFh
			Blink (same as index, except shutter closes between apertures)	192 - 207	75 - 81	C0h - CFh
			Random	208 - 223	82 - 87	D0h - DFh
Reserved	224 - 239		88 - 93	E0h - EFh		
Wheel spin	240 - 255	94 - 100	F0h - FFh			
8	6	<b>Litho wheel position</b>  Position (aperture) selection for blink or index mode (use with ch. 5 (F) or 3 (R))	Position 1 (open)	0 - 15 240 - 255	0 - 5 94 - 100	00h - 0Fh F0h - FFh
			Position 2	16 - 47	6 - 18	10h - 2Fh
			Position 3	48 - 79	19 - 30	30h - 4Fh
			Position 4	80 - 111	31 - 43	50h - 6Fh
			Position 5	112 - 143	44 - 56	70h - 8Fh
			Position 6	144 - 175	57 - 68	90h - AFh
			Position 7	176 - 207	69 - 81	B0h - CFh
			Position 8	208 - 239	82 - 93	D0h - EFh
9	7	<b>Litho rotation (coarse adjustment) and functions</b>	Angular position for blink and index modes	0 - 255	0 - 100	00h - FFh

Table A-1. Technobeam DMX Protocol

Ch. (F)	Ch. (R)	Construct	Parameter	Value (dec.)	Value (%)	Value (hex)
		Random	Random pause time, shortest to longest	0 - 255	0 - 100	00h - FFh
		Scan	Scan rate, slowest to fastest	0 - 255	0 - 100	00h - FFh
		Litho wheel spin (use with ch. 7 (F) or ch. 5 (R))	Forward spin, fastest to slowest	0 - 119	0 - 47	0 - 77h
		Entire wheel spins, not individual lithos	No spin	120 - 135	47 - 53	78h - 87h
			Reverse spin, slowest to fastest	136 - 255	53 - 100	88h - FFh
10	n/a	<b>Litho rotation (fine adjustment)</b>	Angular position for blink and index modes	0 - 255	0 - 100	00h - FFh
11	8	<b>Effects position</b>  Fast effects changes (at beginning of wheel movement)  Select the position with this channel. Then use ch. 12 (F) or ch. 9 (R) to set spin direction and speed.	Position 1	0 - 25	0 - 9	00h - 19h
			Position 2	26 - 51	10 - 20	1Ah - 33h
			Position 3	52 - 76	21 - 29	34h - 4Ch
			Position 4	77 - 102	31 - 40	4Dh - 66h
			Position 5	103 - 127	41 - 49	67h - 7Fh
		Effects changes set by MSpeed (use ch. 16 (F) or 13 (R) to set MSpeed time)  Select the position with this channel. Then use ch. 12 (F) or ch. 9 (R) to set spin direction and speed	Position 1	128 - 153	50 - 60	80h - 99h
			Position 2	154 - 178	61 - 69	9Ah - B2h
			Position 3	179 - 204	70 - 80	B2h - CCh
			Position 4	205 - 229	81 - 89	CDh - E5h
			Position 5	230 - 255	90 - 100	E6h - FFh
12	9	<b>Effects spin speed</b>  (use with ch. 11 (F) or ch. 8 (R))	Forward spin fast to slow forward spin	0 - 120	0 - 47	00h - 78h
			No spin	121 - 134	48 - 52	79h - 86h
			Reverse spin slow to fast forward spin	135 - 255	53 - 100	87h - FFh
13	10	<b>Focus</b>	Variable focus	0 - 255	0 - 100	00h - FFh
14	11	<b>Shutter</b>  Longest ramp time = lowest value (snap time is always short)	Closed	0 - 7	0 - 2	00h - 07h
			Periodic strobe	8 - 67	3 - 26	08h - 43h
			Random strobe	68 - 127	27 - 49	44h - 7Fh
			Ramp open, snap shut	128 - 187	50 - 73	80h - BBh
			Snap open, ramp shut	188 - 247	74 - 96	BCh - F7h
			Open	248 - 255	97 - 100	F8h - FFh
15	12	<b>Dim</b>	Full dark to full bright	0 - 255	0 - 100	00h - FFh
16	13	<b>MSpeed</b>	Movement time (see Table A-3 on page A-13)			

Table A-1. Technobeam DMX Protocol

Ch. (F)	Ch. (R)	Construct	Parameter	Value (dec.)	Value (%)	Value (hex)
17	n/a	Laser Aiming Device (LAD)	LAD off	0 - 7 120 - 127	0 - 3 47 - 49	00 - 07h 78h - 7Fh
			LAD modulate slow to fast <sup>1</sup>	128 - 247	50 - 96	80h - F7h
			LAD on (continuous)	248 - 255	97 - 100	F8h - FFh
		Macros	Macro 1—28 (see Table A-4 on page A-15)			
18	14	Control <sup>2</sup>	Safe <sup>3</sup>	0 - 7	0 - 3	00h - 07h
			Display off	24 - 26	9 - 10	18h - 1Ah
			Display dim	32 - 34	13	20h - 22h
			Display bright	40 - 42	16	28h - 2Ah
			Home <sup>4</sup>	64 - 66	25 - 26	40h - 42h
			Lamp on <sup>5</sup>	80 - 82	31 - 32	50h - 52h
			Lamp off <sup>6</sup>	96 - 98	38	60h - 62h
			Shutdown	128 - 130	50 - 51	80h - 82h

<sup>1</sup> - “Slow” modulation is 4.25 times/sec and “fast” modulation is 255 times/sec, at 50% duty cycle.

<sup>2</sup> - You must set the Shutter channel to zero before accessing the Control channel.

<sup>3</sup> - When set to Safe, the control channel has no effect if the shutter is closed.

<sup>4</sup> - Hold the Control channel at this value for at least one second. Homing the fixture in this way does not change the state of the lamp (if the lamp was off, it stays off; if the lamp was on, it stays on).

<sup>5</sup> - Hold the Control channel at this value for at least one second. If the lamp is currently off, turning the lamp on in this way causes the fixture to home. (If the lamp was already on, the command has no effect.)

<sup>6</sup> - Hold the Control channel at this value for at least one second. The lamp will also turn on whenever you power up the fixture on a link when there is a controller present and it is sending data commands.

## Technobeam-i™ Protocol

Table 2 lists the 18 Technobeam-i constructs and their corresponding DMX controller values. If you have a numeric-type controller, use the Value Decimal (dec.) column. If you have a fader-type controller, use the Value Percentage (%) column. If your controller allows you to program hex values, use the Value (hex) column. The values in the Value

Percentage (%) column may vary slightly depending on your controller's rounding convention.

*Table A-2. Technobeam-i DMX Protocol*

Ch.	Construct	Parameter	Value (dec.)	Value (%)	Value (hex)
1	Pan (mirror) position	Coarse adjustment (8-bit)	0 - 255	0 - 100	00 - FF
2	Pan (mirror) position	Fine adjustment (8-bit)	0 - 255	0 - 100	00 - FF
3	Tilt (mirror) position	Coarse adjustment (8-bit)	0 - 255	0 - 100	00 - FF
4	Tilt (mirror) position	Fine adjustment (8-bit)	0 - 255	0 - 100	00 - FF
5	Color Function	Full Speed Control			
		Indexed	0-15	0-6	00-0F
		Forward Spin	16-31	7-12	10-1F
		Reverse Spin	32-47	13-18	20-2F
		Continuous	48-63	19-25	30-3F
		Slow Scan	64-79	26-31	40-4F
		Fast Scan	80-95	32-37	50-5F
		Random	96-111	38-44	60-6F
		Blink	112-127	45-50	70-7F
		MSpeed Control			
		Indexed	128-143	51-56	80-8F
		Forward Spin	144-159	57-62	90-9F
		Reverse Spin	160-175	63-69	A0-AF
		Continuous	176-191	70-75	B0-BF
		Slow Scan	192-207	76-81	C0-CF
		Fast Scan	208-223	82-88	D0-DF
		Random	224-239	89-94	E0-EF
Blink	240-255	95-100	F0-FF		
6	Color Wheel Position	Indexed and Blink Modes			
		Color 1	0-23	0-9	00-17
		Color 2	24-31	10-12	18-1F
		Color 3	32-39	13-15	20-27
		Color 4	40-47	16-18	28-2F
		Color 5	48-55	19-21	30-37
		Color 6	56-63	22-25	38-3F
		Color 7	64-71	26-28	40-47
		Color 8	72-79	29-31	48-4F
		Color 9	80-87	32-34	50-57
		Color 10	88-95	35-37	58-5F
		Color 11	96-103	38-40	60-67
		Color 12	104-111	41-44	68-6F
		Color 13	112-127	45-50	70-7F
		Colors 1 and 2	128-143	51-56	80-8F
		Colors 2 and 3	144-151	57-60	90-97
		Colors 3 and 4	152-159	61-62	98-9F
		Colors 4 and 5	160-167	63-66	A0-A7
		Colors 5 and 6	168-175	67-69	A8-AF
		Colors 6 and 7	176-183	70-72	B0-B7
Colors 7 and 8	184-191	73-75	B8-BF		
Colors 8 and 9	192-199	76-78	C0-C7		
Colors 9 and 10	200-207	79-81	C8-CF		

Table A-2. Technobeam-i DMX Protocol

Ch.	Construct	Parameter	Value (dec.)	Value (%)	Value (hex)		
6 (cont.)	Color Wheel Position (cont.)	Colors 10 and 11	208-215	82-84	D0-D7		
		Colors 11 and 12	216-223	85-88	D8-DF		
		Colors 12 and 13	224-231	89-91	E0-E7		
		Colors 13 and 1	232-247	92-97	E8-F7		
		Color 1	248-255	98-100	F8-FF		
		Continuously Variable Forward Spin Mode					
		Spin Stop	0-3	0-1	00-03		
		Spin Forward Slowest	4	2	04		
		Spin Forward Fastest	255	100	FF		
		Continuously Variable Reverse Spin Mode					
		Spin Stop	0-3	0-1	00-03		
		Spin Reverse Slowest	4	2	04		
		Spin Reverse Fastest	255	100	FF		
		Continuously Variable Mode					
		Color 1 (open)	0	0	00		
		Color 2	19	8	13		
		Color 3	39	15	27		
		Color 4	58	23	3A		
		Color 5	78	31	4E		
		Color 6	98	38	62		
		Color 7	117	46	75		
		Color 8	137	54	89		
		Color 9	156	61	9C		
		Color 10	176	69	B0		
		Color 11	196	77	C4		
		Color 12	215	84	D7		
		Color 13	235	92	EB		
		Color 1 (open)	255	100	FF		
		Scan Mode - two colors					
		Color 1 and 2	0-23	0-8	00-17		
		Color 2 and 3	24-31	9-12	18-1F		
		Color 3 and 4	32-39	13-15	20-27		
		Color 4 and 5	40-47	16-18	28-2F		
		Color 5 and 6	48-55	19-21	30-37		
		Color 6 and 7	56-63	22-25	38-3F		
		Color 7 and 8	64-71	26-28	40-47		
		Color 8 and 9	72-79	29-31	48-4F		
		Color 9 and 10	80-87	32-34	50-57		
		Color 10 and 11	88-95	35-37	58-5F		
		Color 11 and 12	96-103	38-40	60-67		
		Color 12 and 13	104-111	41-44	68-6F		
		Color 13 and 1	112-127	45-50	70-7F		
		Scan Mode - three colors					
		Color 13 and 1 and 2	128-151	51-59	80-97		
		Color 1 and 2 and 3	152-159	60-62	98-9F		
		Color 2 and 3 and 4	160-167	63-66	A0-A7		
		Color 3 and 4 and 5	168-175	67-69	A8-AF		
		Color 4 and 5 and 6	176-183	70-72	B0-B7		
		Color 5 and 6 and 7	184-191	73-75	B8-BF		
		Color 6 and 7 and 8	192-199	76-78	C0-C7		

Table A-2. Technobeam-i DMX Protocol

Ch.	Construct	Parameter	Value (dec.)	Value (%)	Value (hex)
6 (cont.)	Color Wheel Position (cont.)	Color 7 and 8 and 9	200-207	79-81	C8-CF
		Color 8 and 9 and 10	208-215	82-84	D0-D7
		Color 9 and 10 and 11	216-223	85-88	D8-DF
		Color 10 and 11 and 12	224-231	89-91	E0-E7
		Color 11 and 12 and 13	232-239	92-94	E8-EF
		Color 12 and 13 and 1	240-255	95-100	F0-FF
		Random Mode			
		Random Slowest	0	0	00
	Random Fastest	255	100	FF	
7	Litho Function	Full Speed Control			
		Indexed	0-15	0-6	00-0F
		Forward Spin	16-31	7-12	10-1F
		Reverse Spin	32-47	13-18	20-2F
		Scanning	48-63	19-25	30-3F
		Blink	64-79	26-31	40-4F
		Random	80-95	32-37	50-5F
		Reserved for Future Use	96-111	38-44	60-6F
		Wheel Spin	112-127	45-50	70-7F
		MSpeed Control			
		Indexed	128-143	51-56	80-8F
		Forward Spin	144-159	57-62	90-9F
		Reverse Spin	160-175	63-69	A0-AF
		Scanning	176-191	70-75	B0-BF
		Blink	192-207	76-81	C0-CF
		Random	208-223	82-88	D0-DF
Reserved for Future Use	224-239	89-94	E0-EF		
	Wheel Spin	240-255	95-100	F0-FF	
8	Litho Wheel Position	Indexed, Blink, Spins, and Scanning Modes			
		Litho 1 (open)	0-15	0-6	00-0F
		Litho 2	16-47	7-18	10-2F
		Litho 3	48-79	19-31	30-4F
		Litho 4	80-111	32-44	50-6F
		Litho 5	112-143	45-56	70-8F
		Litho 6	144-175	57-69	90-AF
		Litho 7	176-207	70-81	B0-CF
		Litho 8	208-239	82-94	D0-EF
	Litho 1 (open)	240-255	95-100	F0-FF	
9	Litho Rotate	Indexed Mode			
		Litho Position	0-255	0-100	00-FF
		Scan Mode			
		Slowest Scanning	0	0	00
		Fastest Scanning	255	100	FF
		Random Mode			
		Random Slowest	0	0	00
		Random Fastest	255	100	FF
		Wheel Spin Mode			
		Fastest Forward Wheel Spin	0	0	00
		Slowest Forward Wheel Spin	127	49	7F
		Slowest Reverse Wheel Spin	128	50	80
	Fastest Reverse Wheel Spin	255	100	FF	

Table A-2. Technobeam-i DMX Protocol

Ch.	Construct	Parameter	Value (dec.)	Value (%)	Value (hex)
10	Iris	Close	0	0	00
		Variable Iris	1-127	1-50	01-7F
		Open	128-135	51-53	80-87
		Periodic Strobe	136-151	54-59	88-97
		Random Strobe	152-167	60-66	98-A7
		Ramp Open/Snap Shut	168-183	67-72	A8-B7
		Snap Open/Ramp Shut	184-199	73-78	B8-C7
		Ramp Open/Ramp Shut	200-215	79-84	C8-D7
		Random Ramp Open/Snap Shut	216-231	85-91	D8-E7
		Random Snap Open/Ramp Shut	232-247	92-97	E8-F7
	Open	248-255	98-100	F8-FF	
11	Effects Wheel Position	Full Speed Control			
		Effect 1	0-25	0-10	00-19
		Effect 2	26-51	11-20	1A-33
		Effect 3	52-76	21-30	34-4C
		Effect 4	77-102	31-40	4D-66
		Effect 5	103-127	41-50	67-7F
		MSpeed Control			
		Effect 1	128-153	51-60	80-99
		Effect 2	154-178	61-70	9A-B2
		Effect 3	179-204	71-80	B3-CC
		Effect 4	205-229	81-90	CD-E5
Effect 5	230-255	91-100	E6-FF		
12	Effects Rotate	Rotate Clockwise Fastest	0	0	00
		Rotate Clockwise Slowest	120	47	78
		No rotation	121-134	48-52	79-86
		Rotate Counter-Clockwise Slowest	135	53	87
		Rotate Counter-Clockwise Fastest	255	100	FF
13	Focus	Focus In	0	0	00
		Focus Out	255	100	FF
14	Shutter	Close	0-7	0-3	00-07
		Periodic Strobe	8-67	4-26	08-43
		Random Strobe	68-127	27-50	44-7F
		Ramp Open, Snap Shut	128-187	51-73	80-BB
		Snap Open, Ramp Shut	188-247	74-97	BC-F7
		Open	248-255	98-100	F8-FF
15	Dim	Close	0	0	00
		Continuously Variable	1-254	1-99	01-FE
		Open	255	100	FF
16	MSpeed	See Table A-3 on page A-13 for MSpeed times			
17	Macro/LAD™	LAD Off	0-7	0-3	00-07
		Macro 1	8-11	3-4	08-0B
		Macro 2	12-15	5-6	0C-0F
		Macro 3	16-19	6-8	10-13
		Macro 4	20-23	8-9	14-17
		Macro 5	24-27	9-11	18-1B
		Macro 6	28-31	11-12	1C-1F
		Macro 7	32-35	13-14	20-23
		Macro 8	36-39	14-15	24-27

Table A-2. Technobeam-i DMX Protocol

Ch.	Construct	Parameter	Value (dec.)	Value (%)	Value (hex)
17 (cont.)	Macro/LAD™ (cont.)	Macro 9	40-43	16-17	28-2B
		Macro 10	44-47	17-18	2C-2F
		Macro 11	48-51	19-20	30-33
		Macro 12	52-55	20-22	34-37
		Macro 13	56-59	22-23	38-3B
		Macro 14	60-63	24-25	3C-3F
		Macro 15	64-67	25-26	40-43
		Macro 16	68-71	27-28	44-47
		Macro 17	72-75	28-29	48-4B
		Macro 18	76-79	30-31	4C-4F
		Macro 19	80-83	31-33	50-53
		Macro 20	84-87	32-34	54-57
		Macro 21	88-91	34-36	58-5B
		Macro 22	92-95	36-37	5C-5F
		Macro 23	96-99	38-39	60-63
		Macro 24	100-103	39-40	64-67
		Macro 25	104-107	41-42	68-6B
		Macro 26	108-111	42-44	6C-6F
		Macro 27	112-115	44-45	70-73
		Macro 28	116-119	46-47	74-77
	LAD Off	120-127	47-50	78-7F	
	LAD Modulate Slowest	128	50	80	
	LAD Modulate Fastest	247	97	F7	
	LAD On Continuously	248-255	97-100	F8-FF	
18	Control Note: Shutter (channel 14) must be set to "0" to access the control functions.	Safe	0-7	0-3	00-07
		Display Off	24-26	9-10	18-1A
		Display Dim	32-34	12-13	20-22
		Display Bright	40-42	16-17	28-2A
		Home	64-66	25-26	40-42
		Lamp On	80-82	31-32	50-52
		Lamp Off	96-98	37-38	60-62
		Shutdown	128-130	50-51	80-82

## ***MSpeed Movement Times***

Use Table A-3 to determine the MSpeed (motor/mirror) movement times for Technobeam, Technopro or Technoray in seconds.

An MSpeed (motor/mirror speed) change occurs smoothly over the entire MSpeed time value. For example, if you choose a numerical DMX value of 202 for an MSpeed color change from position 2 to position 4, that means the color wheel changes gradually to position 4 over 11.41 seconds.

**Note** The values displayed in the "Value (%)", "Value (hex)" and "Value (num)" columns may vary slightly depending on your controller's rounding conventions.



Table A-3. MSpeed Movement Times

Time (sec.)	Value (dec.)	Value (%)	Value (hex)	Time (sec.)	Value (dec.)	Value (%)	Value (hex)	Time (sec.)	Value (dec.)	Value (%)	Value (hex)
0.15	255	100	FFh	7.91	211	83	D3h	31.19	167	65	A7h
0.15	254	100	FEh	8.27	210	82	D2h	31.90	166	65	A6h
0.17	253	99	FDh	8.63	209	82	D1h	32.62	165	65	A5h
0.19	252	99	FCh	9.00	208	82	D0h	33.34	164	64	A4h
0.21	251	98	FBh	9.39	207	81	CFh	34.08	163	64	A3h
0.25	250	98	FAh	9.77	206	81	CEh	34.82	162	64	A2h
0.29	249	98	F9h	10.17	205	80	CDh	35.57	161	63	A1h
0.35	248	97	F8h	10.58	204	80	CCh	36.33	160	63	A0h
0.41	247	97	F7h	10.99	203	80	CBh	37.09	159	62	9Fh
0.47	246	96	F6h	11.41	202	79	CAh	37.87	158	62	9Eh
0.55	245	96	F5h	11.84	201	79	C9h	38.65	157	62	9Dh
0.63	244	96	F4h	12.28	200	78	C8h	39.44	156	61	9Ch
0.73	243	95	F3h	12.72	199	78	C7h	40.23	155	61	9Bh
0.83	242	95	F2h	13.17	198	78	C6h	41.04	154	60	9Ah
0.94	241	95	F1h	13.63	197	77	C5h	41.85	153	60	99h
1.05	240	94	F0h	14.10	196	77	C4h	42.68	152	60	98h
1.18	239	94	EFh	14.58	195	76	C3h	43.50	151	59	97h
1.31	238	93	EEh	15.07	194	76	C2h	44.34	150	59	96h
1.45	237	93	EDh	15.56	193	76	C1h	45.19	149	58	95h
1.60	236	93	ECh	16.06	192	75	C0h	46.04	148	58	94h
1.75	235	92	EBh	16.57	191	75	BFh	46.90	147	58	93h
1.92	234	92	EAh	17.09	190	75	BEh	47.77	146	57	92h
2.09	233	91	E9h	17.61	189	74	BDh	48.65	145	57	91h
2.27	232	91	E8h	18.14	188	74	BCh	49.54	144	56	90h
2.46	231	91	E7h	18.68	187	73	BBh	50.43	143	56	8Fh
2.66	230	90	E6h	19.23	186	73	BAh	51.33	142	56	8Eh
2.86	229	90	E5h	19.79	185	73	B9h	52.24	141	55	8Dh
3.07	228	89	E4h	20.36	184	72	B8h	53.16	140	55	8Ch
3.29	227	89	E3h	20.93	183	72	B7h	54.09	139	55	8Bh
3.52	226	89	E2h	21.51	182	71	B6h	55.02	138	54	8Ah
3.76	225	88	E1h	22.10	181	71	B5h	55.96	137	54	89h
4.00	224	88	E0h	22.70	180	71	B4h	56.91	136	53	88h
4.25	223	87	DFh	23.30	179	70	B3h	57.87	135	53	87h
4.52	222	87	DEh	23.92	178	70	B2h	58.84	134	53	86h
4.78	221	87	DDh	24.54	177	69	B1h	59.81	133	52	85h
5.06	220	86	DCh	25.17	176	69	B0h	60.79	132	52	84h
5.34	219	86	DBh	25.80	175	69	AFh	61.78	131	51	83h
5.64	218	85	DAh	26.45	174	68	AEnh	62.78	130	51	82h
5.94	217	85	D9h	27.10	173	68	ADh	63.79	129	51	81h
6.25	216	85	D8h	27.76	172	67	ACh	64.80	128	50	80h
6.56	215	84	D7h	28.43	171	67	ABh	65.82	127	50	7Fh
6.89	214	84	D6h	29.11	170	67	AAh	66.85	126	49	7Eh
7.22	213	84	D5h	29.80	169	66	A9h	67.89	125	49	7Dh
7.56	212	83	D4h	30.49	168	66	A8h	68.94	124	49	7Ch

Table A-3. MSpeed Movement Times

Time (sec.)	Value (dec.)	Value (%)	Value (hex)	Time (sec.)	Value (dec.)	Value (%)	Value (hex)	Time (sec.)	Value (dec.)	Value (%)	Value (hex)
69.99	123	48	7Bh	125.73	78	31	4Eh	197.70	33	13	21h
71.05	122	48	7Ah	127.15	77	30	4Dh	199.48	32	13	20h
72.13	121	47	79h	128.58	76	30	4Ch	201.28	31	12	1Fh
73.20	120	47	78h	130.02	75	29	4Bh	203.08	30	12	1Eh
74.29	119	47	77h	131.47	74	29	4Ah	204.88	29	11	1Dh
75.38	118	46	76h	132.92	73	29	49h	206.70	28	11	1Ch
76.49	117	46	75h	134.39	72	28	48h	208.52	27	11	1Bh
77.60	116	45	74h	135.86	71	28	47h	210.36	26	10	1Ah
78.71	115	45	73h	137.34	70	27	46h	212.19	25	10	19h
79.84	114	45	72h	138.82	69	27	45h	214.04	24	9	18h
80.98	113	44	71h	140.32	68	27	44h	215.90	23	9	17h
82.12	112	44	70h	141.82	67	26	43h	217.76	22	9	16h
83.27	111	44	6Fh	143.33	66	26	42h	219.63	21	8	15h
84.43	110	43	6Eh	144.85	65	25	41h	221.51	20	8	14h
85.59	109	43	6Dh	146.38	64	25	40h	223.40	19	7	13h
86.77	108	42	6Ch	147.92	63	25	3Fh	225.30	18	7	12h
87.95	107	42	6Bh	149.46	62	24	3Eh	227.20	17	7	11h
89.14	106	42	6Ah	151.01	61	24	3Dh	229.11	16	6	10h
90.34	105	41	69h	152.57	60	24	3Ch	231.03	15	6	0Fh
91.55	104	41	68h	154.14	59	23	3Bh	232.96	14	5	0Eh
92.76	103	40	67h	155.71	58	23	3Ah	234.90	13	5	0Dh
93.98	102	40	66h	157.30	57	22	39h	236.84	12	5	0Ch
95.21	101	40	65h	158.89	56	22	38h	238.79	11	4	0Bh
96.45	100	39	64h	160.49	55	22	37h	240.75	10	4	0Ah
97.70	99	39	63h	162.09	54	21	36h	242.72	9	4	09h
98.95	98	38	62h	163.71	53	21	35h	244.70	8	3	08h
100.22	97	38	61h	165.33	52	20	34h	246.68	7	3	07h
101.49	96	38	60h	166.96	51	20	33h	248.68	6	2	06h
102.77	95	37	5Fh	168.60	50	20	32h	250.68	5	2	05h
104.05	94	37	5Eh	170.25	49	19	31h	252.68	4	2	04h
105.35	93	36	5Dh	171.91	48	19	30h	0.19	3	1	03h
106.65	92	36	5Ch	173.57	47	18	2Fh	0.19	2	1	02h
107.96	91	36	5Bh	175.24	46	18	2Eh	0.19	1	0	01h
109.28	90	35	5Ah	176.92	45	18	2Dh	0.19	0	0	00h
110.61	89	35	59h	178.61	44	17	2Ch				
111.94	88	35	58h	180.30	43	17	2Bh				
113.28	87	34	57h	182.01	42	16	2Ah				
114.63	86	34	56h	183.72	41	16	29h				
115.99	85	33	55h	185.44	40	16	28h				
117.36	84	33	54h	187.17	39	15	27h				
118.73	83	33	53h	188.90	38	15	26h				
120.12	82	32	52h	190.65	37	15	25h				
121.51	81	32	51h	192.40	36	14	24h				
122.91	80	31	50h	194.16	35	14	23h				
124.31	79	31	4Fh	195.92	34	13	22h				

# Macro Channel Assignments

Table A-4 below lists the macro channel assignments. *This information is preliminary and subject to change.* A *macro* is predefined set of constructs you can use when programming a scene. You do not have to use macros in your scene, but using them can save you programming time.

Use DMX channel number 17 to access Technobeam macros.

Table A-4. Macro DMX Channel Assignments

Macro Number	Value (dec.)	Value (%)	Value (hex)
off	0 - 7 120 - 255	0 - 3 47 - 100	00h - 07h 78h - FFh
1	8 - 11	4	08h - 0Bh
2	12 - 15	5	0Ch - 0Fh
3	16 - 19	6 - 7	10h - 13h
4	20 - 23	8 - 9	14h - 17h
5	24 - 27	10	18h - 1Bh
6	28 - 31	11 - 12	1Ch - 1Fh
7	32 - 35	13	20h - 23h
8	36 - 39	14 - 15	24h - 27h
9	40 - 43	16	28h - 2Bh
10	44 - 47	17 - 18	2Ch - 2Fh
11	48 - 51	19 - 20	30h - 33h
12	52 - 55	21	34h - 37h
13	56 - 59	22 - 23	38h - 3Bh
14	60 - 63	24	3Ch - 3Fh
15	64 - 67	25 - 26	40h - 43h
16	68 - 71	27	44h - 47h
17	72 - 75	28 - 29	48h - 4Bh
18	76 - 79	30	4Ch - 4Fh
19	80 - 83	31 - 32	50h - 53h
20	84 - 87	33 - 34	54h - 57h
21	88 - 91	35	58h - 5Bh
22	92 - 95	36 - 37	5Ch - 5Fh
23	96 - 99	38	60h - 63h
24	100 - 103	39 - 40	64h - 67h
25	104 - 107	41	68h - 6Bh
26	108 - 111	42 - 43	6Ch - 6Fh
27	112 - 115	44 - 45	70h - 73h
28	116 - 119	46	74h - 77h

# Fixture Number to DMX Start Channel

Table A-5 below shows the conversion between fixture number and DMX start channel. You must understand and use this information if you choose to control Technobeam using fixture numbering.

Table A-5. Fixture Number to DMX Start Channel Conversion

Fixture Number	DMX Start Channel 18-ch. (TB F, TB I)	DMX Start Channel 14-ch. (TB R)
1	1	1
2	19	15
3	37	29
4	55	43
5	73	57
6	91	71
7	109	85
8	127	99
9	145	113
10	163	127
11	181	141
12	199	155
13	217	169
14	235	183
15	253	197
16	271	211
17	289	225
18	307	239
19	325	253
20	343	267
21	361	281
22	379	295
23	397	309
24	415	323
25	433	337
26	451	351
27	469	365
28	487	379
29		393
30		407
31		421
32		435
33*		449
34*		463
35*		477
36*		491

\* - A link with more than 32 fixtures requires a serial data distributor to regenerate and retime the signal.

# Appendix B

## Factory-Installed Wheels

This appendix shows how the litho wheel, rotating litho wheel, color wheel and effects wheels are configured by the factory when Technobeam is shipped. The numbers shown around the outside of the wheels are the position numbers used by a controller to select that effect. For example, choosing position 6 on the Technobeam rotating litho wheel (see Figure B-1) with a controller selects the “Rip Wheel” litho.

### **Technobeam™ Wheels**

---

Technobeam rotating litho wheel:

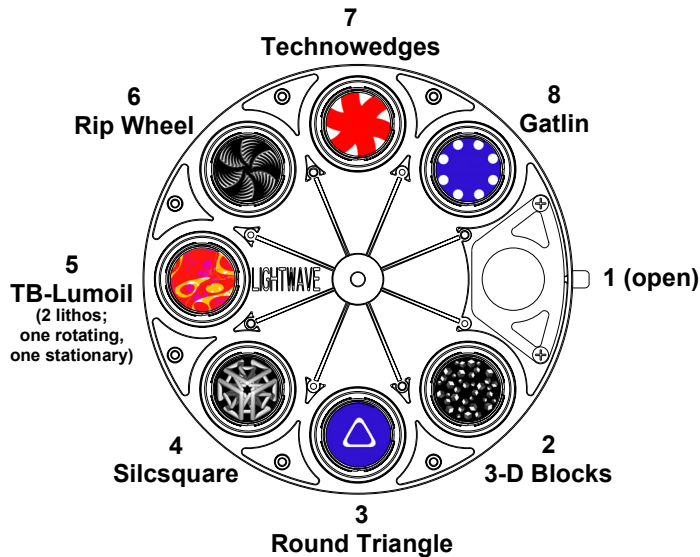

Figure B-1. Factory configuration of the Technobeam rotating litho wheel.

Technobeam color wheel:

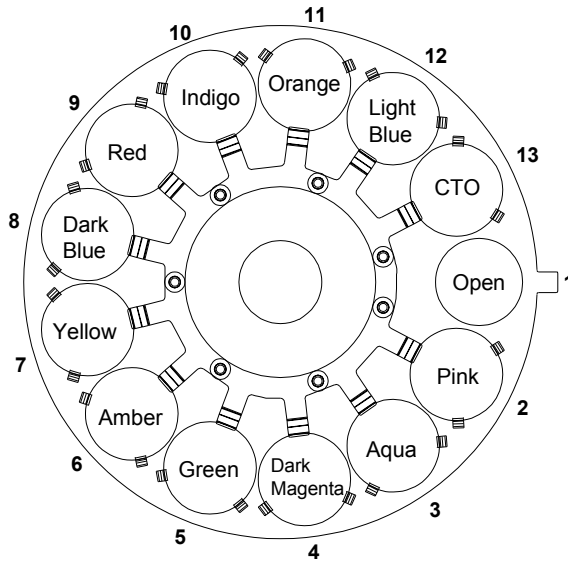

Figure B-2. Factory configuration of the Technobeam color wheel.

Technobeam rotating effects wheel:

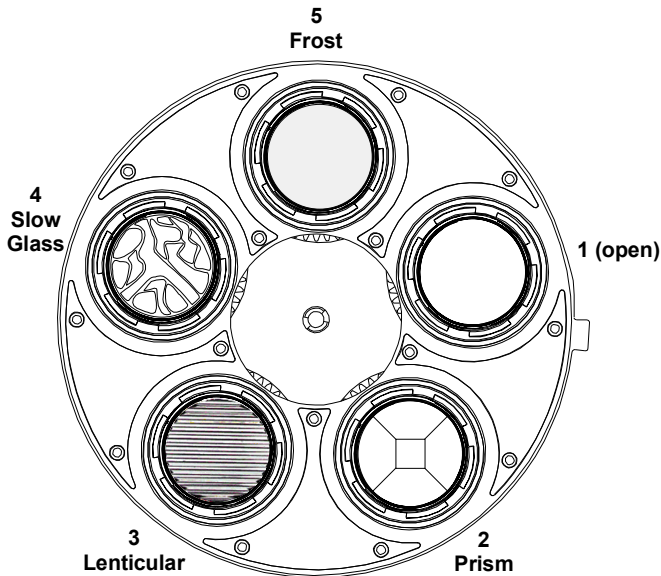

Figure B-3. Factory configuration of the Technobeam rotating effects wheel.

# Appendix C

# Important Safety

# Information

## *English Version*

---

### **Warning: For Continued Protection Against Fire**

1. This equipment is designed for use with Phillips M Series 250 watt, GY9.5 base metal halide lamp only. Use of any other type lamp may be hazardous and may void the warranty.
2. Do not mount on a flammable surface.
3. Maintain minimum distance of 1.0 meter (3.28 feet) from combustible materials.
4. Replace fuses only with the specified type and rating.
5. Observe minimum distance to lighted objects of 1.0 meter (3.28 feet).
6. This equipment for connection to branch circuit having a maximum overload protection of 20 A.

### **Warning: For Continued Protection Against Electric Shock**

1. If this equipment was received without a line cord plug, attach the appropriate line cord plug according to the following code:
  - brown–live
  - blue–neutral
  - green/yellow–earth
2. As the colours of the cores in the mains lead of this equipment may not correspond with the coloured markings identifying the terminals in your plug, proceed as follows:
  - the core which is coloured green and yellow must be connected to the terminal in the plug which is marked with the letter E or by the earth symbol , or coloured green or green and yellow.
  - the core which is coloured blue must be connected to the terminal which is marked with the letter N or coloured black.
  - the core which is coloured brown must be connected to the terminal which is marked with the letter L or coloured red.
3. Class I equipment. This equipment must be earthed.
4. Disconnect power before re-lamping or servicing.
5. Equipment suitable for dry locations only. Do not expose this equipment to rain or moisture.
6. Refer servicing to qualified personnel; no user serviceable parts inside.

### **Warning: For Continued Protection Against Exposure To Excessive Ultraviolet (UV) Radiation**

1. Do not operate this equipment without complete lamp enclosure in place or if shields, lenses, or ultraviolet screens are damaged.
2. Change shields, lenses, or ultraviolet screens if they have become visibly damaged to such an extent that their effectiveness is impaired, for example by cracks or deep scratches.
3. Never look directly at the lamp while lamp is on.

### **Warning: For Continued Protection Against Injury To Persons**

1. Use secondary safety cable when mounting this fixture.
2. Caution: hot lamp may be an explosion hazard. Do not open for 5 minutes after switching off. Wear eye and hand protection when re-lamping.
3. Equipment surfaces may reach temperatures up to 140 degrees C (284 degrees F). Allow 5 minutes for cooling before handling.
4. Change the lamp if it becomes damaged or thermally deformed.

## **Appendice C IMPORTANT: INFORMATIONS DE SÉCURITÉ**

---

### **Mise en garde: pour une protection permanente contre les incendies**

1. Cet appareil est conçu uniquement pour une lampe métallique à halogène Philips série M, de 250 watts, à base GY9.5. Son utilisation avec tout autre type de lampe peut être dangereuse et annuler la garantie.
2. Ne pas monter les lampes sur une surface inflammable.
3. Maintenir à une distance minimum de 1.0 mètre de matières inflammables.
4. Ne remplacer les fusibles qu'avec des modèles et valeurs assignées recommandés.
5. Respecter une distance minimum de 1.0 mètre par rapport aux objets éclairés.
6. Cet appareil de connection au circuit comporte une protection contre les surcharges de 20 A.

### **Mise en garde: pour une protection permanente contre les chocs électriques**

1. Si cet équipement est livré sans prise de cable, veuillez connecter la prise de cable correcte selon le code suivant:
  - marron - phase
  - bleu - neutre
  - vert/jaune - terre
2. Débrancher le courant avant de changer les lampes ou d'effectuer des réparations.
3. Cet équipement doit être uniquement utilisé dans des endroits secs. Ne pas l'exposer à la pluie ou l'humidité.
4. À l'intérieur de l'équipement il n'y a pas de pièces remplaçables par l'utilisateur. Confiez l'entretien à un personnel qualifié.
5. Equipement de Classe I. Cet équipement doit être mis à la terre.



### **Mise en garde: pour une protection permanente contre des expositions excessives aux rayons ultra violets (UV)**

1. Ne pas utiliser cet appareil si le boîtier de la lampe n'est pas complètement fixé ou si les blindages, lentilles, ou écrans ultraviolets sont endommagés.
2. Changer les blindages ou les écrans ultraviolets s'ils sont visiblement endommagés au point que leur efficacité aient été altérée, par exemple par des fissures ou de profondes égratignures.
3. Ne jamais regarder directement la lampe quand celle ci est allumée.

### **Mise en garde: pour une protection permanente contre les blessures corporelles**

1. Lors de l'assemblage, utiliser un câble de sécurité secondaire.
2. AVERTISSEMENT: les lampes chaudes comportent un risque d'explosion. Après l'avoir éteinte, attendre 5 minutes avant de la dégager. Lors du remplacement de la lampe, une protection des yeux et des mains est requise.
3. Les surfaces de l'appareil peuvent atteindre des températures de 140 C. Laisser refroidir pendant 5 minutes avant la manipulation.
4. Changer la lampe si elle est endommagée ou thermiquement déformée.

## **Anhang C Wichtige Hinweise Für Ihre Sicherheit**

---

### **WARNUNG: ZUM SCHUTZ VOR BRANDGEFAHR**

1. Dieses Gerät ist nur für den Gebrauch mit einer 250-Watt, Philips Serie M, Metall-Halogen-Lampe mit GY9.5-Sockel konzipiert. Der Gebrauch irgend eines anderen Lampentyps könnte Sie gefährden und Ihre Garantie außer Kraft setzen.
2. Das Gerät nie auf einer feuergefährlichen Fläche montieren.
3. Stets einen Mindestabstand von 1 Meter zu brennbaren Materialien einhalten.
4. Zum Ersatz nur Sicherungen verwenden, die dem vorgeschriebenen Typ und Nennwert entsprechen.
5. Einen Mindestabstand von 1 Meter zu den angestrahlten Objekten einhalten.
6. Dieses Gerät darf nur an eine Zweigleitung mit einem Überlastungsschutz von höchstens 20 A angeschlossen werden.

### **WARNUNG: ZUM SCHUTZ GEGEN GEFÄHRLICHE KÖRPERSTRÖME**

1. Wenn dieses Gerät ohne einen Netzkabelstecker erhalten wurde, ist der entsprechende Netzkabelstecker entsprechend dem folgenden Code anzubringen:
  - Braun - Unter Spannung stehend
  - Blau - Neutral
  - Grün/Gelb - Erde
2. Vor dem Austauschen von Lampen oder vor Wartungsarbeiten stets den Netzstecker ziehen.
3. Diese Geräte sind nur zum Einbau in trockenen Lagen bestimmt und müssen vor Regen und Feuchtigkeit geschützt werden.

4. Servicearbeiten sollten nur von Fachpersonal ausgeführt werden. Das Gerät enthält keine wartungsbedürftigen Teile.
5. Dieses Gerät gehört zur Klasse I. Dieses Gerät muß geerdet werden.

### **WARNUNG: ZUM SCHUTZ GEGEN ÜBERMÄSSIGE ULTRAVIOLETT (UV)-BESTRAHLUNG**

1. Benutzen Sie dieses Gerät nur, wenn das komplette Lampengehäuse fest eingebaut ist; ebenfalls dürfen keine der Schutzabdeckungen, Linsen oder der UV-Schutz Beschädigungen aufweisen.
2. Die Schutzabdeckungen, Linsen und der UV-Schutz müssen ausgewechselt werden, wenn sie sichtlich dermaßen beschädigt sind, daß sie ihre Wirksamkeit einbüßen, z.B. infolge von Rissen oder tiefen Kratzern.
3. Nie direkt in die eingeschaltete Lampe schauen.

### **WARNUNG: ZUM SCHUTZ VOR VERLETZUNGEN**

1. Verwenden Sie bei der Installation des Beleuchtungskörpers ein zusätzliches Sicherheitskabel.
2. VORSICHT: Bei einer heißen Lampe besteht Explosionsgefahr. Nach dem Abschalten der Netzspannung sollten Sie etwa 5 Minuten warten, bevor Sie das Lampengehäuse öffnen. Schützen Sie beim Auswechseln der Lampen Ihre Hände und tragen Sie eine Schutzbrille.
3. Die Oberflächen des Gerätes können Temperaturen bis zu 65 C erreichen. Vor dem Anfassen stets 5 Minuten lang abkühlen lassen.
4. Falls die Lampe beschädigt oder durch Wärmeeinwirkung verformt ist, muß sie ausgewechselt werden.

## **Appendice C Importanti Informazioni Di Sicurezza**

---

### **AVVERTENZA: PER PREVENIRE INCENDI:**

1. Questa apparecchiatura è stata progettata per l'uso esclusivo con lampada a sali metallici Philips da 250 watt, base GY9.5, serie M. L'uso di qualsiasi altro tipo di lampada può essere pericoloso e può annullare la garanzia.
2. Da non montare sopra una superficie infiammabile.
3. Mantenere l'apparecchio a un minimo di 1.0 metri (3.28 piedi) di distanza dai materiali combustibili.
4. Rimpiazzare i fusibili usando soltanto quelli del tipo e della taratura adatta.
5. Mantenere una distanza minima di 1.0 metri (3.28 piedi) dagli oggetti accesi.
6. Questa apparecchiatura e' da collegarsi ad un circuito con una protezione da sovraccarico massima di 20 ampères.

### **AVVERTENZA: PER PREVENIRE LE SCOSSE ELETTRICHE:**

1. Se questa apparecchiatura è stata consegnata senza una spina del cavo di alimentazione, collegare la spina appropriata del cavo di alimentazione in base ai seguenti codici:
  - marrone - sotto tensione
  - blu - neutro
  - verde/giallo - terra
2. Disinnestare la corrente prima di cambiare la lampadina o prima di eseguire qualsiasi riparazione.
3. Questa apparecchiatura e' da usarsi in ambienti secchi. Non e' da essere esposta ne alla pioggia ne all' umidita'.
4. Per qualsiasi riparazione rivolgersi al personale specializzato. L' utente non deve riparare nessuna parte dentro l' unita'.
5. Aparecchio di Classe I. Questa apparecchiatura deve essere messa a terra.

### **AVVERTENZA: PER PROTEGGERSI CONTRO LE RADIAZIONI DEI RAGGI ULTRAVIOLETTI:**

Non usare questa apparecchiatura se il sistema di chiusura della lampadina non e' completo o se gli scudetti, le lenti, o gli schermi ultravioletti si sono visibilmente danneggiati di maniera tale che la loro efficacia sia stata ridotta --- ad esempio, se vi sono visibili spaccature o graffi profondi. Mai guardare direttamente verso la lampadina quando sia accesa.

### **AVVERTENZA: PER NON FERIRE AD ALTRE PERSONE:**

1. Al montare questa apparecchiatura, usare un secondo cavo di sicurezza.
2. Avvertenza: la lampadina calda potrebbe esplodere. Spegnerla per 5 minuti prima di aprirla. Usare protezioni per le mani e per gli occhi prima di cambiare la lampadina.
3. Le superfici della apparecchiatura possono arrivare a temperature di 65 gradi centigradi (149 gradi f). Aspettare 5 minuti prima di maneggiare.
4. Cambiare la lampadina se si danneggia o se si e' deformata dovuto alle alte temperature.

## **Apéndice C Información Importante De Seguridad**

---

### **ADVERTENCIA: PARA PROTECCIÓN CONTINUA CONTRA INCENDIOS:**

1. Este equipo está diseñado para utilizarse únicamente con la lámpara de haluro metálico Philips serie M, de 250 vatios y base GY9.5. El uso de cualquier otro tipo de lámpara puede resultar peligroso, pudiendo anular la garantía.
2. No monte el equipo sobre una superficie inflamable.
3. Mantenga una distancia mínima de materiales combustibles de 1.0 metro.
4. Cambie los fusibles únicamente por otros que sean del tipo y la clasificación especificadas.
5. Conserve una distancia mínima a objetos iluminados de 1.0 metro.
6. Este equipo debe conectarse a un circuito que tenga una protección máxima contra las sobrecargas de 20 A.

## **ADVERTENCIA: PARA LA PROTECCIÓN CONTINUA CONTRA ELECTROCUCIONES**

1. Si se recibió este equipo sin el enchufe de alimentación, monte usted el enchufe correcto según el clave siguiente:
  - moreno - vivo
  - azul - neutral
  - verde/amarillo - tierra.
2. Desconecte el suministro de energía antes de recambiar lámparas o prestar servicio de reparación.
3. Este equipo se adecua a lugares secos solamente. no lo exponga a la lluvia o humedad.
4. Derive el servicio de reparación de este equipo al personal calificado. el interior no contiene repuestos que puedan ser reparados por el usuario.
5. Equipo de Clase I. Este equipo debe conectarse a la tierra.

## **ADVERTENCIA: PARA PROTECCIÓN CONTINUA CONTRA LA EXPOSICIÓN A RADIACIÓN ULTRAVIOLETA (UV) EXCESIVA**

1. No opere este equipo sin tener colocada en su lugar la caja protectora completa de la lámpara o bien, si el blindaje , los lentes o las pantallas ultravioletas están dañadas.
2. Cambie el blindaje, los lentes o las pantallas ultravioleta si nota una avería visible, a tal grado que su eficacia se vea comprometida. Por ejemplo, en el caso de grietas o rayaduras profundas.
3. Jamás mire directamente a la lámpara en tanto ésta esté encendida.

## **ADVERTENCIA: PARA PROTECCIÓN CONTINUA CONTRA LESIONES CORPORALES**

1. Use cable secundario de seguridad al montar este aparato.
2. Precaución: una lámpara caliente puede constituir un peligro de explosión. No la abra por 5 minutos luego de haberla apagado. Lleve puestos, un protector ocular, y guantes al recambiar lámparas.
3. Las superficies del equipo pueden alcanzar temperaturas máximas de 65 grados centígrados. Deje que se enfrien por 5 minutos antes de tocarlas.
4. Cambie la lámpara si ésta se avería o deforma por acción térmica.

# **Vigtig Sikkerhedsinformation - DANMARK**

---

Advarsel: Beskyttelse mod elektrisk chock.

Vigtigt!

Lederen med gul/groen isolation maa kun tilsluttes en klemme maerket



eller



# INDEX

---

## A

Accessories ..... 1-5  
Addr Lost ..... 2-25  
Address menu (ADDR) ..... 3-10  
Aligning LAD ..... 6-19 to 6-25  
Anti-reflective glass ..... 6-16  
Aperture ring ..... 6-8  
Arc lamp ..... intro-2

---

## B

Beam angle, setting ..... 1-12 to 1-14  
Beam angles ..... 1-14  
Boot Diff ..... 2-25

---

## C

Cabling  
    constructing ..... 2-5  
    terminators ..... 2-5  
Capturing presets ..... 4-11  
C-clamps  
    ordering ..... 1-5  
    using ..... 2-10  
Channel range ..... 2-16  
    assigning ..... 2-15  
    overlapping ..... 2-16  
Chase ..... 4-2  
Cleaning fixture ..... 6-15 to 6-18  
Coated side of dichroic ..... 6-6  
Construct ..... 4-2  
Constructing cabling ..... 2-5  
Control method  
    changing (CHNL) ..... 3-13  
    selecting ..... 2-14  
Controlling Laser Aiming Device . 5-5  
Crossload ..... 3-19  
Crossloading ..... 2-19  
Custom lithos ..... 6-11  
Customer Service ..... intro-4

---

## D

Dichroics  
    coated side ..... 6-6  
    replacing ..... 6-5 to 6-7  
Dimensions ..... 1-2  
Display ..... 2-13  
DMX 512  
    cabling ..... 2-4  
    cabling specifications ..... 1-5  
    constructing cabling ..... 2-5  
    control commands not  
        accepted ..... 2-22  
        explanation ..... 2-4  
        fixture number conversion . A-16  
        linking devices ..... 2-7  
        setting up link ..... 2-6 to 2-8  
        terminator ..... 2-5  
        troubleshooting ..... 2-24  
DMX 512 protocol  
    Technobeam ..... A-3 to A-7  
    Technobeam-i ..... A-7 to A-12  
DMX channel range ..... 2-15  
DMX start channel ..... 2-14  
    determining ..... 2-16  
DMX start channel control  
    method ..... 2-14  
DMX wasted channels ..... 2-17  
Down arrow key ..... 3-2

---

## E

Effects, replacing ..... 6-7 to 6-11  
EIA RS-485 ..... 2-5  
Electrical specifications ..... 1-2  
EMEM  
    CHNL ..... 2-26  
    DPLY ..... 2-26  
    FHRS ..... 2-26  
    L/ST ..... 2-26  
    LENS ..... 2-26  
    LHRS ..... 2-26  
    MODE ..... 2-26

PERS .....	2-26
PINV .....	2-26
S/DN .....	2-26
SWAP .....	2-26
TIMB .....	2-26
TINV .....	2-26
EMEM Ack .....	2-26
Enter key .....	3-2
Environmental specifications .....	1-5
Erse Flsh .....	2-26

---

## F

Factory defaults (FACT) .....	3-11
Factory-installed wheels .....	B-1, B-2
Fan failed .....	2-21
Fast change .....	4-3
Features .....	intro-1
Fixture	
accessories .....	1-5
cleaning .....	6-15 to 6-18
controllers .....	1-5
crossloading .....	2-18, 2-20
dichroic, litho, effects	
specifications .....	1-4
DMX 512 data .....	2-24
factory-installed wheels .....	B-1, B-2
features .....	intro-1
homing .....	2-2
installing power cord cap .....	1-7
keys .....	3-2
lamp .....	intro-2
LEDs .....	2-3, 2-4
macros .....	4-2
menu .....	3-3
mounting .....	2-8 to 2-11
powering on .....	2-2
preset programming .....	4-2 to 4-9
programming .....	4-2 to 4-9
reflector .....	intro-1
replacing a lamp .....	6-11 to 6-14
replacing fuses .....	6-2 to 6-4
safety standards .....	1-4
setting beam angle .....	1-12 to 1-14
setting voltage .....	1-10, 1-11
specifications .....	1-2 to 1-5
troubleshooting .....	2-20 to 2-24
uploading .....	2-18, 2-20

wheels .....	B-1, B-2
yoke .....	2-12
installing .....	1-8, 1-9
Fixture address, assigning .....	2-15
Fixture number .....	2-14
determining .....	2-17
Fixture number control method .....	2-14
Fixture number conversion .....	A-16
Fixture options .....	3-10
Fixture type .....	2-13
setting the fixture type	
(TYPE) .....	3-15
Focus drive screw .....	1-13, 6-17
Fuses .....	1-2
replacing .....	6-2 to 6-4

---

## H

Hanging fixture .....	2-8 to 2-11
Help .....	intro-4
Homing .....	2-2
Homing the fixture	
manually (HOME) .....	3-20
Hot mirror .....	6-18

---

## I

ID Lost .....	2-26
Installing lenses .....	1-12 to 1-14
Installing lithos .....	6-9
Installing the yoke .....	1-8, 1-9

---

## L

Lamp .....	intro-2
optimizing .....	6-14
turning on or off (LAMP) .....	3-20
Lamp not working .....	2-20
Lamp or replacing .....	6-11 to 6-14
Lamp warning message, setting	
(LMPL) .....	3-14
Laser Aiming Device (LAD)	
aligning .....	6-19 to 6-25
controlling .....	5-5
ideal position .....	5-4

maintenance .....	6-19 to 6-25
recommended operation .....	5-3
safety .....	5-2
specifications .....	1-2
troubleshooting .....	5-6 to 5-8
LED display .....	2-13
changing the output (DSPL) .....	3-13
inverting (D/IN) .....	3-13
LEDs	
Emission Indicator .....	5-7, 5-8
Motor .....	2-3, 2-4
Receive .....	2-3, 2-4
Transmit .....	2-3, 2-4
Lenses, installing .....	1-12 to 1-14
Light source .....	intro-2
Line cord cap, installing .....	1-7
Link Busy .....	2-27
Link Empty .....	2-27
Link, setting up .....	2-6 to 2-8
Linking fixtures .....	2-7
Lithos	
aperture ring .....	6-8
cleaning .....	6-8
cracked .....	2-22
custom .....	6-11
installing .....	6-9
replacing .....	6-7 to 6-11
specifications .....	1-4
LM01 .....	5-5
LM30 .....	5-5
Look .....	4-2
Loop .....	4-2
LROF .....	5-5
LRON .....	5-5

---

## M

Macros .....	4-2, A-1, A-15
Menu key .....	3-2
Menu system, accessing .....	3-2
Mode menu (MODE) .....	3-15
Model numbers .....	1-2
Motor LED .....	2-3, 2-4
Mounting fixture .....	2-8 to 2-11
MSpeed change .....	4-3
MSpeed movement times .....	A-12 to A-14

---

## N

Narrow angle lens set .....	1-14
Navigation buttons .....	2-13
Navigational keys .....	3-2

---

## O

Optimizing the lamp .....	6-14
Optional accessories .....	1-5
Optoisolators .....	2-6
Orienting lithos .....	6-9
Over Temp .....	2-28

---

## P

Page .....	4-2
Pan	
inverting (P/IN) .....	3-12
swapping pan and tilt (SWAP) .....	3-12
PGRM Time .....	2-28
Power cord cap, installing .....	1-7
Powering on fixture .....	2-2
Preset programming	
capturing .....	4-11
chase .....	4-2
construct .....	4-2
example .....	4-4 to 4-9
fast change .....	4-3
loop .....	4-2
macros .....	4-2
MSpeed change .....	4-3
synchronizing .....	4-9 to 4-11
Programming	
capturing presets .....	4-11
chase .....	4-2
construct .....	4-2
example .....	4-4 to 4-9
fast change .....	4-3
loop .....	4-2
macros .....	4-2
MSpeed change .....	4-3
synchronizing .....	4-9 to 4-11
Protocol, fixture specific .....	2-13

PRST Lost ..... 2-28

---

## R

Receive LED ..... 2-3, 2-4  
Reflector ..... intro-1  
Replacing a lamp ..... 6-11 to 6-14  
Rotating litho ..... 6-10

---

## S

Safety standards ..... 1-4  
Sample program ..... 4-4 to 4-9  
Serial data distributor ..... 2-6  
Set menu (SET) ..... 3-11  
Setting fixture voltage ..... 1-10, 1-11  
Setting up DMX 512 link .... 2-6 to 2-8  
Shut Down ..... 2-28  
Software  
    crossloading ..... 2-18, 2-20  
    crossloading (XLD) ..... 3-19  
    uploading ..... 2-18, 2-20  
Specifications ..... 1-2 to 1-5  
    controllers ..... 1-5  
    dichroics ..... 1-4  
    dimensions ..... 1-2  
    DMX 512 cabling ..... 1-5  
    effects ..... 1-4  
    electrical ..... 1-2  
    environmental ..... 1-5  
    lithos ..... 1-4  
    model numbers ..... 1-2  
    safety ..... 1-4  
    weight ..... 1-2  
Static litho ..... 6-8, 6-9  
Synchronizing preset playback .... 4-9

---

## T

Technical Support ..... intro-4  
Terminator ..... 2-5  
Terminators ..... 2-5  
Test menu (TEST) ..... 3-20  
Tilt  
    inverting (T/IN) ..... 3-12

---

    swapping pan and tilt  
    (SWAP) ..... 3-12  
Transmit LED ..... 2-3, 2-4  
Troubleshooting ..... 2-20 to 2-24  
Truss ..... 2-9

---

## U

United States Institute of Theatre  
Technology. *See* USITT  
Unpacking ..... 1-6  
Up arrow key ..... 3-2  
Updating fixture software . 2-18, 2-20  
Uploading ..... 2-18  
User presets  
    copying (PRST) ..... 3-17  
    copying presets and settings  
    (ALL) ..... 3-18  
User settings  
    copying (SETT) ..... 3-18  
    copying user presets and  
    settings (ALL) ..... 3-18  
User type, setting (USER) ..... 3-16  
Using laser ..... 5-3  
USITT ..... 2-4

---

## V

Viewing DMX 512 data ..... 2-24  
Voltage, setting ..... 1-10, 1-11

---

## W

Weight ..... 1-2  
Wheels ..... B-1, B-2

---

## Y

Yoke  
    adjusting ..... 2-12  
    installing ..... 1-8, 1-9

---